



WORKING DATA CATALOGUE

2020

This catalogue represents the basic information needed to start designing a Bally Walk-In or Refrigerated Building. Each chapter includes complete descriptive and technical information about Bally products. To avoid repetition, details common to Walk-Ins and Refrigerated Buildings have been included in the chapters on general design and layout, floors, doors, accessories and refrigeration systems. The section on architectural specifications applies to Coolers and Freezers of all sizes.

- 1** GENERAL DESIGN INFORMATION
- 2** DOORS
- 3** FLOORS
- 4** ACCESSORIES
- 5** BLAST CHILLERS
- 6** REFRIGERATED BUILDINGS
- 7** LAYOUT SUGGESTIONS
- 8** SPECIFICATIONS
- 9** REFRIGERATION EQUIPMENT

CALL US TODAY AT 1-800-24BALLY.

ALPHABETICAL INDEX

	Section	Page
A		
Adapt-A-Door	2	12
Alarms, Temperature	2	9
Approvals	1	6
B		
Back-to-back 'Z' Purlins	6	26
Blast chillers	5	21
Built-in floors, insulation thickness	3	13
Built-in floors, NSF Certified	3	13
Bumper guards	4	19
C		
Cantilevered shelving, adjustable	4	18
Cart Doors, Double-swing	2	10
Ceiling panels, self-supported	6	27
Clearance requirements	7	30
Condensers	9	38
Condensing units	9	38
Construction, Doors	2	8
Construction, Floors	3	13
Construction, Panels	1	4
Construction, Refrigerated Buildings	6	24
D		
Dimensions, Double-swing Cart Doors	2	10
Dimensions, Hinged Doors	2	7
Doors, Adapt-A-Door	2	12
Doors, Construction	2	8
Doors, Double-swing Cart	2	10
Doors, Glass Display	2	11
Doors, Hinged Entrance	2	7
Doors, Hinged Reach-In Service	2	11
Doors, locating	7	29
Doors, Sliding Entrance	2	10
Doors, Super	2	8
E		
Edge caps, floor & ceiling	4	19
Entrance door ramps	4	20
Evaporators	9	38
F		
Finishes, metal	1	4
Floors	3	13
Floors, NSF Certified	3	13
Floors, Construction	3	13
Floors, maximum loads	3	13
Floors, Warehouses	6	28
G		
Glass Display Doors	2	11
H		
Heater wire circuits, doors	2	9
Hinged entrance doors	2	7
Hinged Reach-In service doors	2	11
Hinges	2	9
I		
'I' Beam structural steel	6	25
Insulation Thickness, floors	3	13
Insulation	1	6

	Section	Page
L		
Latches	2	9
Lights, Florescent, LED, Vapor-proof	4	19
Loading limits, Panels	7	24
Loading limits, Refrigeration	7	30
Locating doors	7	29
Locking bar	2	9
M		
Maximum floor loads	3	13
Metal finishes	1	4
Modular shelving, adjustable	4	18
Multi-Span Panels	6	23
N		
Northwind Blast Chiller	5	21
NSF Certified, Floors	3	13
O		
Observation windows, doors	2	9
P		
Panels, Construction	1	4
Panel Dimensions	7	31
Panels, Multi-Span	6	23
Panels, Sizes	1	4
Pallet Rack Support	6	27
Partitions	4	17
Perforated drain & vent pipes	3	16
Pre-assembled Remote Refrigeration	9	37
Pressure Relief Ports	2	9
R		
Ramps	4	20
Reach-In Service Doors	2	11
Refrigerated Buildings	6	23
Refrigeration Equipment	9	37
Roofs	4	20
Rub Rails	4	19
S		
Safety release, doors	2	9
Self-supported ceiling panels	6	27
Shelving	4	18
Sizes, Panels	1	4
Sliding Entrance doors	2	10
Specifications	8	33
Speed-Loks	1	5
Steplates	2	12A
Strip curtains	2	9
Structural steel	6	25
Super doors	2	8
Suspended ceilings	6	25
T		
Temperature alarm	4	19
Thermometers	2	9
V		
Vaporproof lights	4	19
Vertical Panel Anchoring	3	13
Vertical Panel Support	6	25
W		
Warehouse Floors	6	28
Windows, observation	2	9
Wire Shelving	4	18

1

GENERAL DESIGN INFORMATION

BALLY IS ONE OF THE MOST EXPERIENCED AND INNOVATIVE MANUFACTURERS OF WALK-INS AND REFRIGERATED STRUCTURES

Bally has been a leader in the cold storage industry since we introduced Insulated Refrigerated Structures more than 80 years ago. Bally is responsible for many advances in technology that are now considered standard manufacturing practices.

Today, we remain faithful to our tradition of innovation. Bally pioneered the use of non-ozone depleting panels and our panels were the first to receive FM Class I, and UL listings. To comply with the Energy Independence Security Act of 2007, Bally introduced the use of HFC-245fa into our foam. Through our many developments, we've continued to rely on the outstanding fundamentals of our product line, features like these that set us apart:

- **Foamed-in-place, non-ozone depleting urethane insulation.** Our foam uses a low pressure expanding agent that produces 98% closed-cell insulation; maintaining exact thicknesses and precise edges while performing at temperatures ranging from -80°F (-62.2°C) to 200°F (93.3°C).
- **Fast, easy assembly.** Our precisely formed, lightweight panels are available in 4", 5", or 6" thicknesses. The Bally Speed-Lok joining system allows our Walk-Ins and Refrigerated Buildings to be quickly and easily transported and assembled at the job site.
- **Refrigeration Systems.** Bally Refrigeration Products provide a number of pre-assembled remote Refrigeration Systems. They are available in varied designs, mounting styles, capacities, and voltages. Refrigeration Systems are individually configured so they have the correct size, power and capacity for each Bally structure.



GENERAL DESIGN

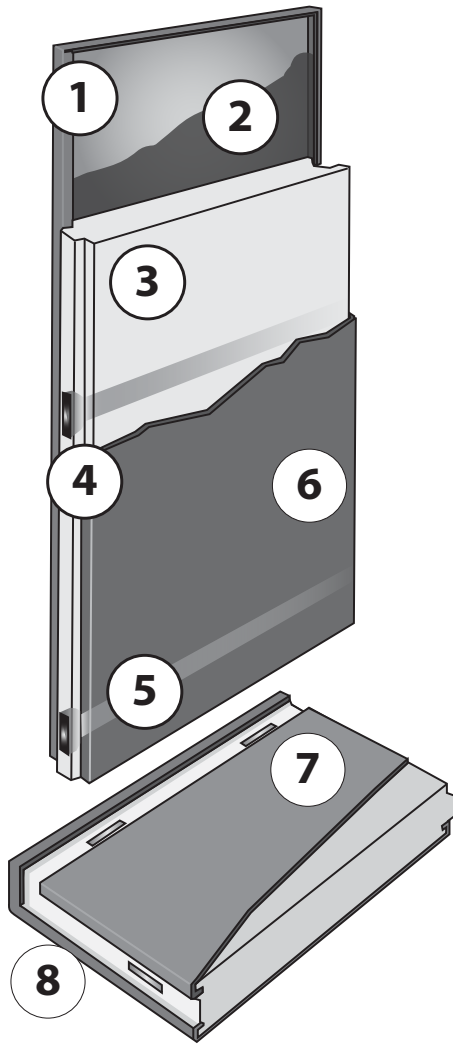

Smallest building size is 3'11" x 5'10".
Size increases in 11½" increments.

Our panels are precisely formed in custom-designed molds then injected with foam insulation to provide dimensional stability through a wide range of temperatures.

1. Exterior metal vertical panel skins. (See below for available finishes.)
2. Bally wash primer for optimum foam adhesion.
3. Foamed-in-place, non-ozone depleting urethane insulation.
4. Accurately molded urethane creates tongue and groove edges.
5. Speed-Lok joining mechanism creates snug joints with heavy-gauge steel straps that connect locking arms with locking pins on opposite edges of each panel.
6. Interior metal vertical panel skin. (See below for available finishes.)
7. Interior metal floor panel skin. (See below for available finishes.)
8. Exterior metal floor panel skin. Edges capped with matching metal when Stainless steel or White galvanized steel is specified for vertical. (See below for available finishes.)

Verticals	Heights:	6'10"-10'10", 11'4"-19'4", 19'8"-27'8" In 1' increments. (May be fabricated in 2 pieces)
	Widths:	11½", 17¼", 23", 34½", or 46" Corners 12" x 12" Outside width
Ceiling & Floor	End:	23½" Widths
	Center:	11½", 17¼", 23", 34½", or 46" Widths
Hinged Entrance Doors 4" 5", or 6"	Heights:	6'10", 7'10" (For taller buildings, correctly sized panels are installed above the door panels.)
	Widths:	46" wide panels: 24", 30", 34", 36" openings 57½" wide panels: 36", 42", 48" openings 69" wide panels: 36", 42", 48", or 60" openings

Heights shown are for vertical panels only; for overall height, add thickness of appropriate floor and ceiling panels. Lengths vary. 4" and 5" thick floor and ceiling panel maximum length: 11'6" multi-span; 17'4" for single span (*indoors*). Beading occurs on panels greater than 130" in height to improve stability; panels shorter than 130" are not beaded.

PANEL FINISHES

Bally panels are constructed with standard metal finishes. *Custom options and colors are available.*

Vertical Panel Finishes

Stainless steel
Galvanized steel
Smooth White galvanized steel
Smooth White aluminum
Stucco-Embossed Galvalume steel
Stucco-Embossed Stainless steel
Stucco-Embossed Aluminum
Stucco-Embossed White Aluminum
Stucco-Embossed White galvanized steel
Stucco-Embossed Sand-tan galvanized steel

Floor Metal and Diamond Tread Finishes

16 ga. Stainless Steel
.080 Rigidized Aluminum
.100 Smooth Aluminum
16 ga. Galvanized Steel
.125 Aluminum Diamond Tread
.060 Rigidized Stainless Steel

GENERAL DESIGN

THE BALLY SPEED-LOK

Bolstered by a steel strap foamed into the panels, Bally Speed-Loks help to create strong structures. The Speed-Lok's simplicity allows a structure to be assembled in a fraction of the time compared to conventional construction and aids in the ability to expand, disassemble, or relocate a Bally structure with ease. The Bally Speed-Lok is operated solely by a hex wrench, and consists of:

- **Locking pin:** This steel rod is precisely positioned so that the locking arm engages it tightly.
- **Locking arm:** A cam-mounted arm with a hooked end. When a hex wrench is used to turn the arm, the eccentric movement of the cam first enables the hook to engage the pin and then draws the panels tightly together.

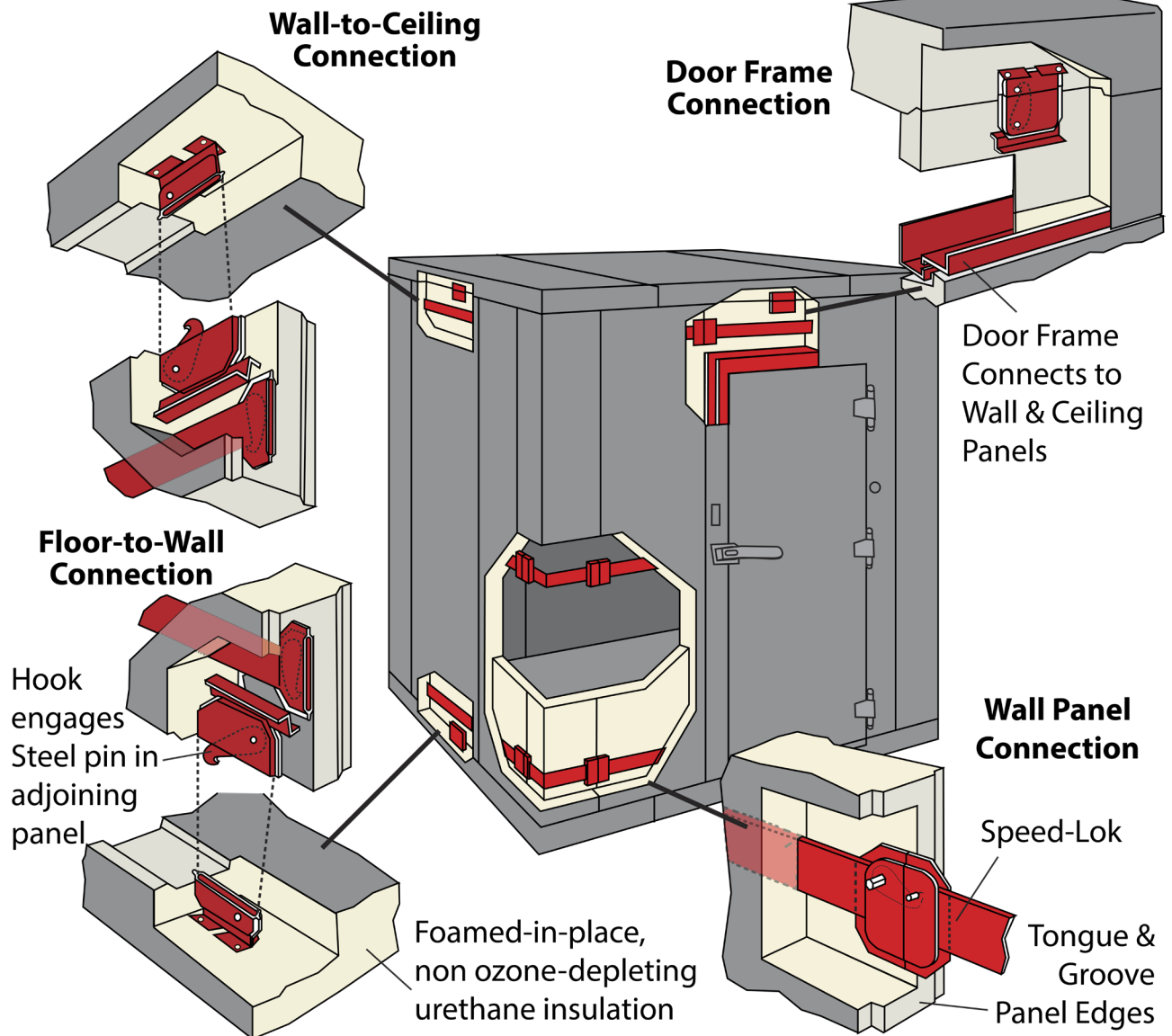
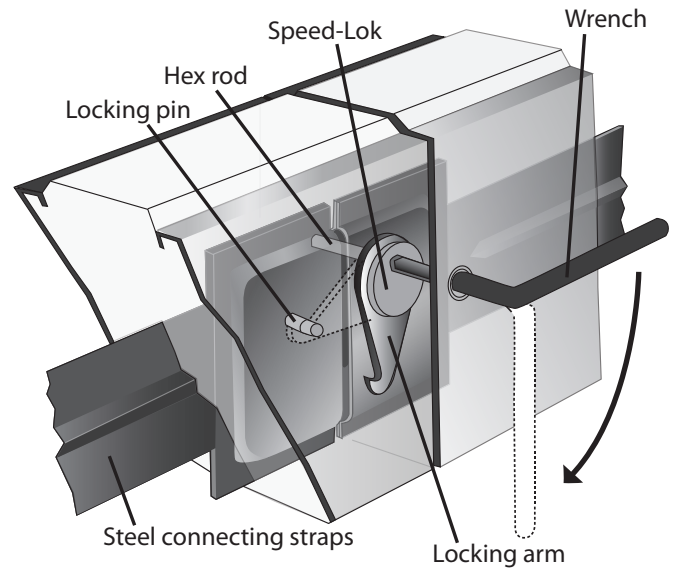

GENERAL DESIGN

BALLY PANEL INSULATION

The current insulation formula used in Bally panels relies on Hydrofluorocarbon (HFCs), specifically HFC-245fa, meeting standards for Chlorofluorocarbon (CFC) reduction, the U.S. Clean Air Act, and the EISA Act of 2007. Compared to the CFCs they replace, HFCs reduce ozone depletion by a factor of ten while creating insulation with outstanding resistance to the transfer of heat. Urethane insulation is substantially more effective at resisting the transfer of heat than other common insulating materials. Advantages of Bally Insulation:

- **Dimensional stability:** Bally's non-ozone depleting urethane uses a low pressure expanding agent that produces 98% closed-cell insulation that maintains its shape and size through a wide range of temperatures.
- **Lightweight:** Poured-foam urethane insulation makes Bally panels light in weight, so they are easy to handle during installation.
- **Energy efficiency:** The insulating superiority of a Bally structure reduces energy expenditures resulting in cost savings.

INSULATION RATINGS

Bally Insulation	K-Factor	R-Value		
		4"	5"	6"
Cooler Panels	.137	29.2	36.5	43.9
Freezer Panels	.123	32.6	40.8	48.9

In 2009, federal law went into effect requiring Walk-In Cooler and Freezer panels to contain insulation with ratings of at least R-25 for Coolers and R-32 for Freezers. R-values and K-factors measure thermal resistance and heat conductivity which are determined by ASTM c518. Coolers are tested at 55°F mean temperature with a 40° temperature difference. Freezers are tested at 20°F mean temperature with a 40° temperature difference.

LAWS, APPROVALS & LISTINGS

Our products are in compliance with the Energy Independence and Security Act of 2007, and additionally backed with approvals and listings from leading independent quality certification organizations. Buyers can be sure that Bally products live up to these stringent standards.

EISA

Bally panels and refrigeration systems are in accordance with the Energy Independence and Security Act of 2007.



Underwriters Laboratories

Flame spread and smoke developed listings appear on tags on every Bally panel; proving that the panels are UL-classified. UL listings have also been granted to electrical systems in Bally structures, including interior lights, door heaters and refrigeration systems.



Factory Mutual

Bally panels have been approved as a Class 1 building material by Factory Mutual Insurance System. This approval means that Bally wall and ceiling panels meet FM standards for Walk-Ins and Refrigerated Buildings without sprinklers. *(Local codes vary)*



National Sanitation Foundation

Bally installations that incorporate floor panels with a 3/8" coved offset are Certified by NSF.



New York City

Stringent tests on our insulation have earned Bally panels the Materials and Equipment Approval of the City of New York. To conform to the standards Bally makes special wiring systems and low-voltage heaters when needs dictate.



City of Houston

Tests on our panels have earned Bally the City of Houston Approval.



Miami Dade

Bally has received approval from Miami-Dade County, Florida NOA # 17-0830.08 Expires: 2.7.2023



Contact factory regarding other approvals.

1.800.24BALLY | www.ballyrefboxes.com

2

DOORS

Bally Doors are designed and certified for use in walk-in coolers or freezers.

DEPEND ON BALLY FOR LONG LIFE AND RELIABLE SERVICE

Our doors use the same construction as our panels: rigid insulation foamed-in-place and securely bonded to metal skins for tremendous structural strength. A reinforced U-channel steel frame with a thermal breaker prevents twisting, sagging, and eliminates the need for structural members. The durability of this construction results in an exceptionally strong door.

- Bally doors include fingertip-touch latch with lock set. A magnetic gasket provides a snug seal.
- Heater wires concealed in the perimeter of Bally door jambs prevent the formation of condensation or frost.
- Bally offers a wide selection of sizes and options.

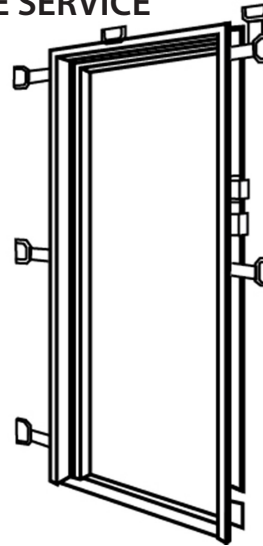

DIMENSIONAL DATA:

Hinged Entrance Door Panels

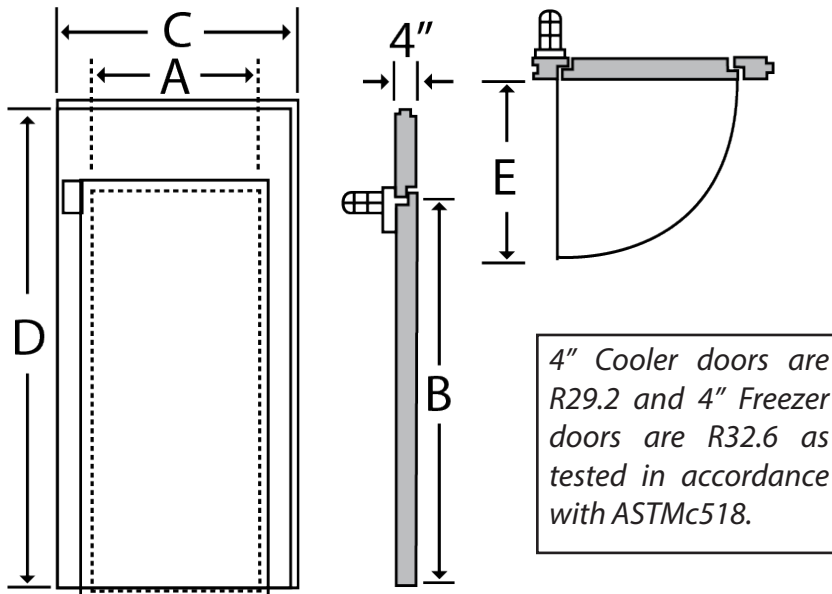

	Door Opening		Door Panels Used w/ Floor Panels		
	A	B	C*	D	E
7'6" High Walk-In	2'6"	6'6"	3'10"	6'10"	3'1"
	2'6"	6'6"	5'9"	6'10"	3'1"
	3'0"	6'6"	3'10"	6'10"	3'7"
	3'0"	6'6"	5'9"	6'10"	3'7"
	3'6"	6'6"	5'9"	6'10"	4'1"
	4'0"	6'6"	5'9"	6'10"	4'7"
8'6" High Walk-In	5'0"	6'6"	5'9"	6'10"	5'6"
	2'6"	6'6"	3'10"	7'10"	3'1"
	2'6"	6'6"	5'9"	7'10"	3'1"
	2'6"	7'0"	3'10"	7'10"	3'1"
	2'6"	7'0"	5'9"	7'10"	3'1"
	3'0"	6'6"	3'10"	7'10"	3'7"
	3'0"	6'6"	5'9"	7'10"	3'7"
	3'0"	7'0"	3'10"	7'10"	3'7"
	3'0"	7'0"	5'9"	7'10"	3'7"
	3'6"	6'6"	5'9"	7'10"	4'1"
	3'6"	7'0"	5'9"	7'10"	4'1"
	4'0"	6'6"	5'9"	7'10"	4'7"
	4'0"	7'0"	5'9"	7'10"	4'7"
5'0"	7'0"	5'9"	7'10"	5'6"	

120V, 60Hz, 1 Phase service is required for lights and anti-condensate heaters on door panels (220V available). Connections are made to the junction box at the light, which is always inside the Walk-In, directly opposite the top hinge.

**Total amps include anti-condensate heaters and one 8-watt compact florescent light.

*Consult factory for details. 4'9 1/2" door panel available for 30", 36", 42" and 48" door openings requiring special locations. For 6'6" Walk-Ins, 5'6" high door openings can be supplied. Partition door panels, when used with floor panels, are identical to exterior door panels except that the stepplate is flush. For Walk-Ins higher than 8'6", an additional filler wall panel is used above an 8'6" high door panel.

Door Size (inches)	Total Amps		Energy Consumption kWh/day	
	Cooler	Freezer	Cooler	Freezer
30x78	0.83	2.14	1.75	7.11
36x78	1.19	2.11	2.11	7.25
42x78	0.79	1.94	2.23	7.51
48x78	1.13	1.94	2.27	7.59
60x78	1.07	2.39	2.32	8.91
36x84	1.13	1.94	2.08	7.17
42x84	1.1	1.94	2.22	7.49
48x84	1.07	2.39	2.25	8.63
60x84	1.02	2.71	2.31	9.74

DOORS

STANDARD HINGED 30"-36" & 42" DOORS

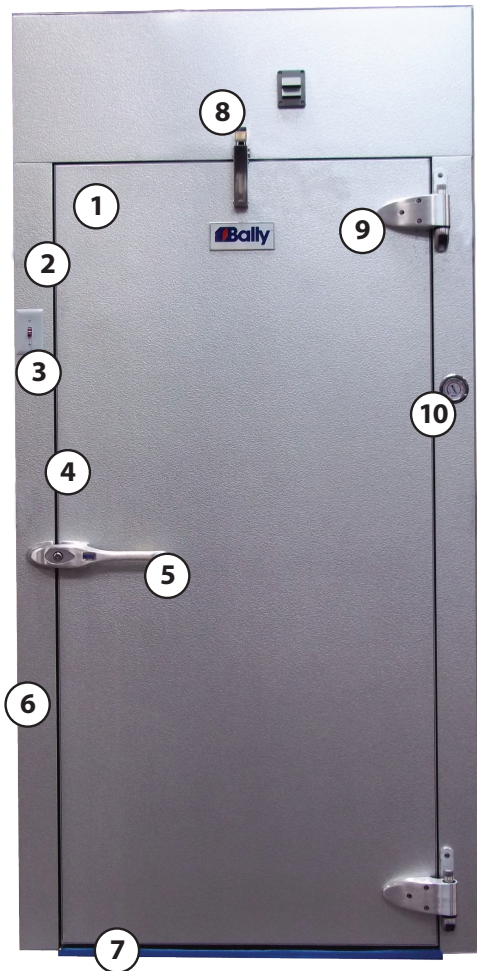

1. Inside and outside doorcaps are die-formed (See page 4 for available finishes).
2. Magnetic gasket of soft compression plastic with magnetic core keeps door tightly sealed.
3. Toggle switch with pilot light for interior light.
4. Heater wires are concealed around perimeter of the door frame to prevent formation of frost or condensation.
5. Fingertip-touch latch with lock set easily opens the door. Available with special provision for padlocking. *Finish matches hinges.*
6. Bally insulation in 4", 5", or 6" thickness.
7. Dual wiper-type gasket at the bottom of the door provides a tight seal.
8. Door closer.
9. Hinges with zinc-plated steel pins and Delrin bushings are cam-action, spring-loaded, and self-closing. Supplied with protective plastic caps. *Finishes: Satin, polished aluminum, or chrome-finish.*
10. Built-in, flush-face, dial type thermometer (*Field mounted in 60" doors*).
11. Serial number tag; use as reference for future orders.
12. Inside safety release.
13. Strap-type hinges. *Finishes: Satin, polished aluminum, chrome finished cast metal.*
14. Positive door latch.

STANDARD 48" & 60" WIDE DOORS

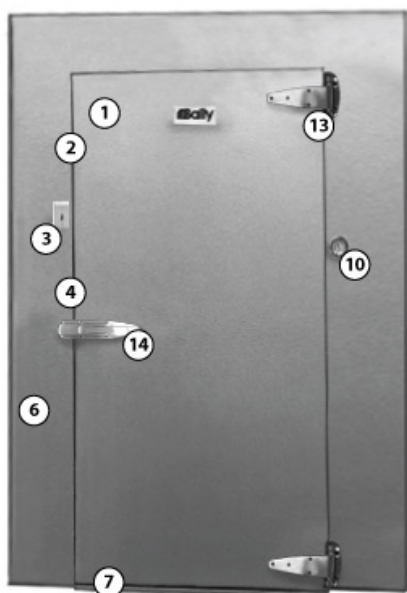

SUPER DOORS

For the most rugged applications, these hinged doors are shielded inside and outside by Diamond Tread kickplates, and are provided with extra support by an added third hinge. The Super Door is designed to take hard use with little or no damage, especially in high-traffic locations. Available in all standard sizes and with many options.



DOORS

STANDARD FEATURES

BUILT-IN THERMOMETER

Flush-face, dial-type thermometer mounted with each 30", 36", 42", and 48" wide entrance door. Dual temperature readings from -60°F (-50°C) to 80°F (30°C). (60" doors require field mounting.)



INSIDE SAFETY RELEASE

All locks are connected to a safety release mounted inside the Walk-In. Turning the handle allows for immediate release. (Supplied on 30", 34", 36", and 42" doors. Field mounted on 48" & 60" wide doors.)



SELF-CLOSING HINGES (30", 34", 36", 42" WIDE DOORS)

Bally cam-action, spring-loaded hinges are built to last with zinc-plated steel pins, Delrin bushings, and protective plastic caps. Finishes: satin or polished aluminum.



STRAP HINGES (48" AND 60" WIDE DOORS)

These heavy-duty strap-type hinges give extra support, with three supplied on each door. Finishes: satin or polished aluminum.



DOOR LATCH (30"- 36" AND 42" WIDE DOORS)

Bally's fingertip-touch latch easily opens our standard doors. The latch includes a key lock. Finishes match hinges.



POSITIVE DOOR LATCH (48" AND 60" WIDE DOORS)

Sturdy latches are rugged for use with bigger doors. Finishes match hinges.



DOOR HEATER CIRCUIT

A heating circuit mounted in the door jamb prevents moisture buildup in Coolers and frost formation in Freezers.

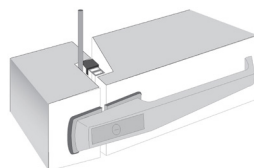

OPTIONS

OBSERVATION WINDOW

Bally observation windows are made of tempered glass and electrically heated to eliminate condensation (115V, .87 amps). Windows are 14" wide x 24" long, or 14" x 14".



PRESSURE RELIEF PORTS

Pressure relief ports allow air pressure inside the building to equalize with air pressure on the outside. The difference in pressure results from temperature changes that occur immediately following coil defrost, or opening the entrance door. Without the port, wall or ceiling panels could be seriously damaged. (Required on all Freezer applications.)



DIGITAL THERMOMETERS AND ALARMS

Digital thermometers may be selected in place of the standard dial type. Each incorporates a visual signal and sounds an alarm when temperatures rise above acceptable limits. (Indoor applications only.) Electronic temperature alarms are also available.



LOCKING BARS

Locking bars are available for all Bally hinged entrance doors. The bars protect against theft especially for outdoor installations. Even if hinges are removed, the bar prevents the door from opening.

STRIP CURTAINS

Bally's NSF Certified vinyl strip curtains minimize air infiltration and temperature loss. Polyester reinforced clear vinyl strips are 8" wide with rounded edges and USDA-approved. Use for temperatures as low as -20°F. Hinged Doors: 30", 36", 42", 48", and 60" widths. Manual Sliding Doors: 36", 48", and 60" widths. Panels sized 6' x 8'.

See Section 4 for more accessories.

DOORS

SLIDING ENTRANCE DOORS



Made in a variety of sizes to fit individual specifications, manual or electrically operated sliding entrance doors include provisions for locking, an interior safety release, and electric heaters to eliminate condensation. Available as single or bi-parting doors in all standard finishes. Consult factory for details.

DOUBLE SWING CART DOORS

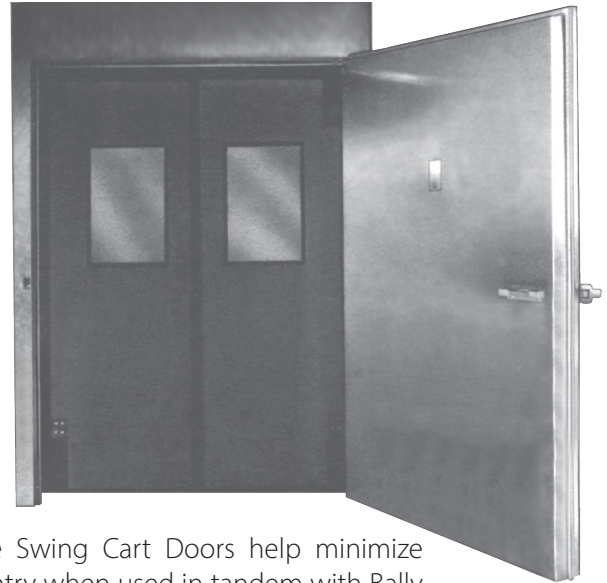

Double Swing Cart Doors help minimize heat entry when used in tandem with Bally doors that must be kept open. The doors are made to withstand heavy use from pallet jacks, cargo carts, and hand trucks.

Double Swing Cart Door Opening			
Leaf	A	B	C
Single	2'6"	6'6"	2'3"
	2'6"	7'0"	2'3"
	2'10"	6'6"	2'7"
	2'10"	7'0"	2'7"
	3'0"	6'6"	2'9"
	3'0"	7'0"	2'9"
Single or double	4'0"	6'6"	3'6"*
	4'0"	7'0"	3'6"*
Double	5'0"	6'6"	4'6"
	5'0"	7'0"	4'6"
	6'0"	6'6"	5'6"
	6'0"	7'0"	5'6"
	6'0"	8'0"	5'6"

*Add 3" if single-leaf.

Double Swing Cart Doors are available in single or double leaf models; mounted on sturdy steel frames designed for easy field installation with Bally doors on Walk-Ins with operating temperatures as low as -40°F. The doors are adjustable vertically and horizontally, and can be used with Bally floor panels or with built-in floors.

- Doors are made of insulation sandwiched between NSF Certified high-impact polyethylene skins.
- The hinges have flexible seals and are gasketed on all sides.
- V-cams and bottom hinges are self-lubricating.
- Recessed polycarbonate windows exceed OSHA minimums.
- All hardware is plated or anodized.

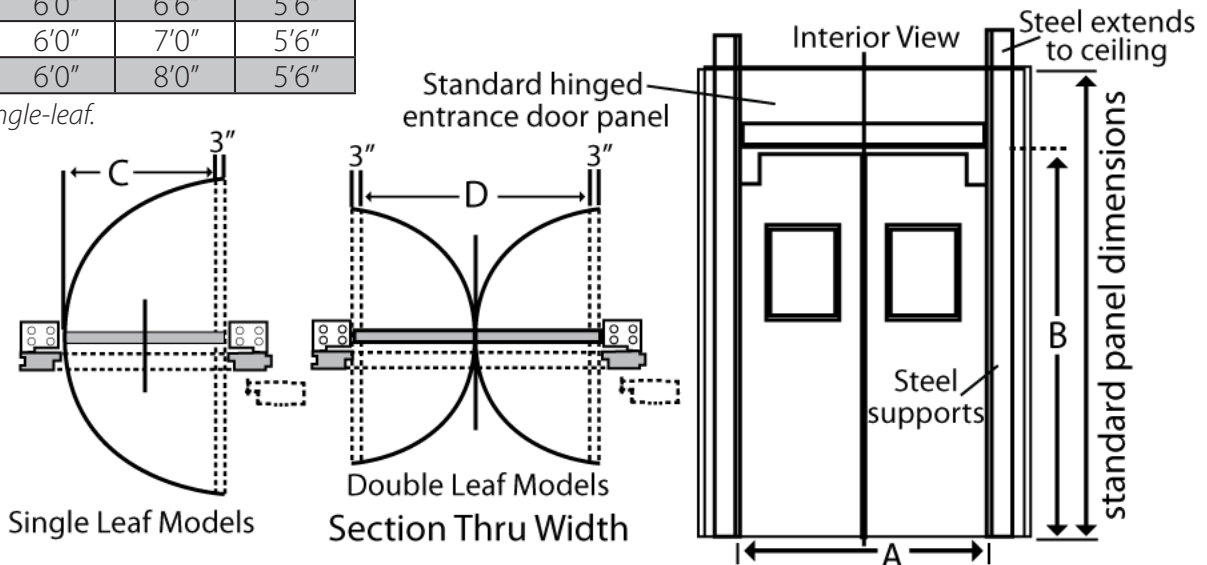

DOORS

HINGED GLASS DISPLAY DOORS

Full-height hinged glass display doors for Cooler or Freezer applications stimulate impulse buying and can boost sales dramatically.

- Narrow door frames provide maximum display.
- Wide openings make self-service easy.
- Doors are glazed with multiple glass units with air spaces between.
- Built-in heaters eliminate condensation
- All doors can be installed with left-hand or right-hand swings.

Available locks add security.
(Consult factory for particular project needs.)



SLIDING GLASS DISPLAY DOORS

It's easy to equip Walk-Ins for self-service use by installing sliding glass display doors. Multi-glass units with insulating air spaces between panes are mounted in narrow aluminum frames to provide maximum serviceability. Two sizes of doors are available, with two doors in each set. Sliding doors are available for medium temperature use and in multiples of two. (Consult factory for particular project needs.)

HINGED REACH-IN SERVICE DOORS

Convenient reach-in doors are made in two sizes:

- 18½" x 30" openings in 23" and 34½" wide panels
- 30" x 30" openings in 46" wide panels

Sill heights are 26" for single doors and 29" for panels with two doors.

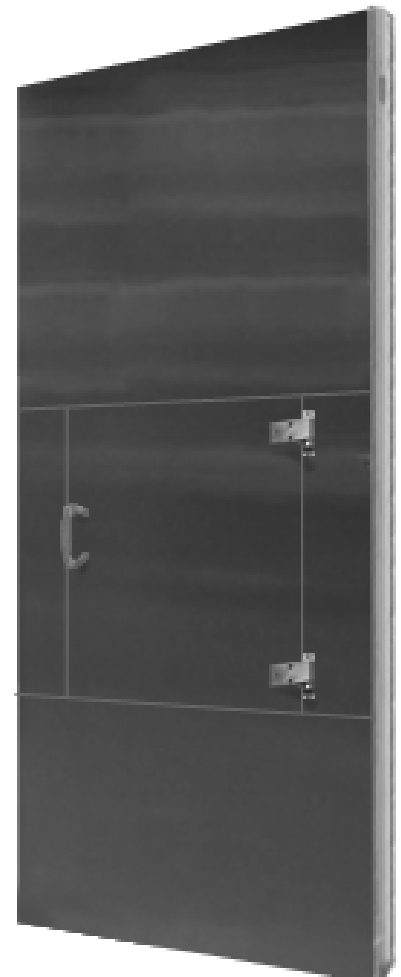
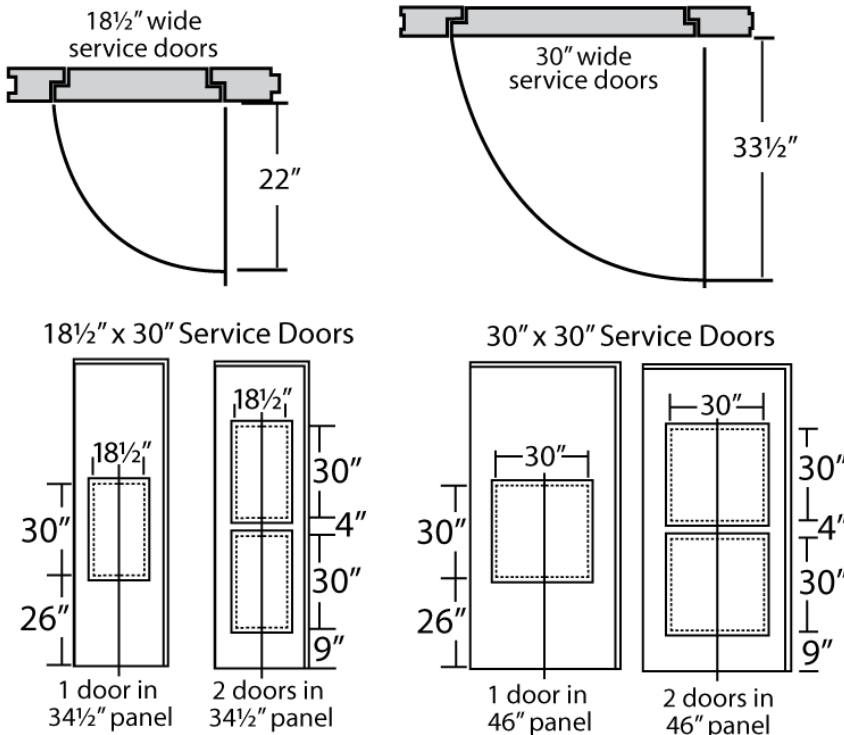



THE ADAPT-A-DOOR

The versatile Bally Adapt-A-Door makes it easy to replace a worn-out, broken or ill-fitting door or easily install a new door. The Adapt-A-Door can be used with Bally panels, other insulating panels, or cut it into an ordinary masonry wall.

Bally's Adapt-A-Door will swing freely and seal tightly for years because it's supported by heavy-duty hinges, a durable latch assembly, and is composed of our non-ozone depleting urethane insulation sandwiched between metal skins.

Standard Adapt-A-Door Widths, Heights and Finishes

- Finishes: Stainless steel, Stucco-Embossed Galvalume, Stucco-Embossed Aluminum, Stucco-Embossed White Galvanized Steel
- Widths: 30", 36", 42", 48" and 60"
- Heights: 66" through 84"

TWO JAMB TYPES

Type A:

Supplied with a front-face frame only. Use when replacing an existing door or anywhere the existing wall provides adequate frame support.

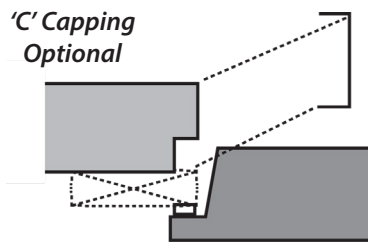

Type B:

Supplied with front frame and 4" thick inside jamb. Use to cut in a new door or when existing frame support is inadequate.

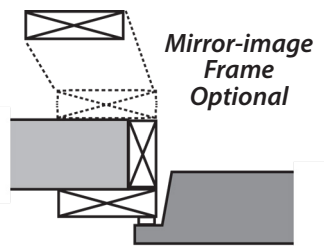

THREE ADAPT-A-DOOR STYLES

1 Cooler door with 3-sided frame

Loop heaters are located in the frame.

Use For: Less-Floor Coolers; new, replacement, retrofit

2 Freezer door with 3-sided frame

Same as #1, but with additional bottom heater and gasket.

Use For: Less-Floor Freezers; replacement, retrofit

3 Door with 4-sided frame

Heat and gasketing around perimeter of the door frame.

Use For: Raised Insulated Floors; new, replacement, retrofit

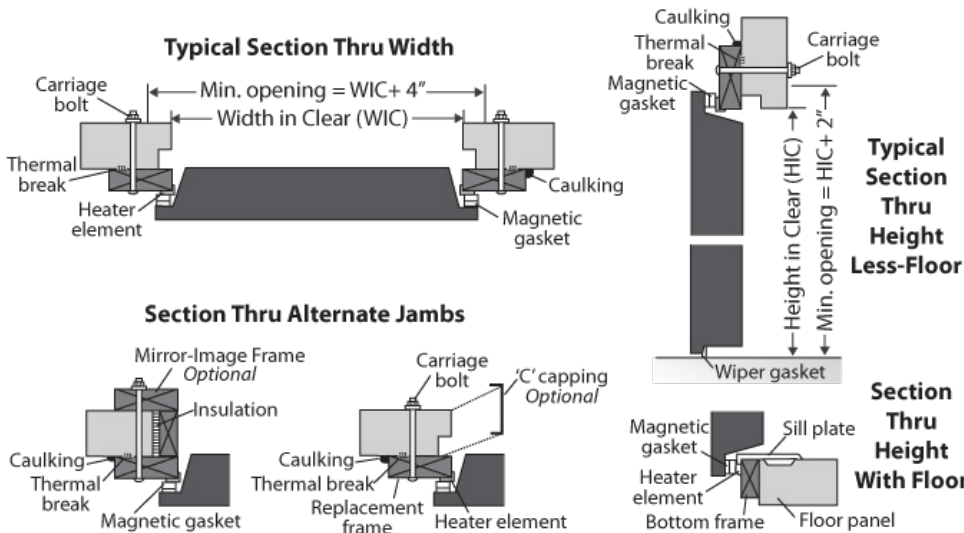

OPTIONS

Mirror-Image Frame: Extra support for inner side of door opening.

C-capping: Trims opening

Inside Trim Strip: Use in place of mirror-image frames to trim inner surface on Type B jambs.

Z-trim: Use with Type B jambs only in applications with walls thicker than 4".

Locking Bar

Diamond Tread Kickplates

Observation Windows

DOORS

STEPPLATES

Bally has every type of Stepplate to fit your specific needs.

Stepplate Types:

Screed: The Screed step plate is flat and is meant to be installed at the door threshold directly on the building floor.

Fastening methods would be determined by the walk-in installer.

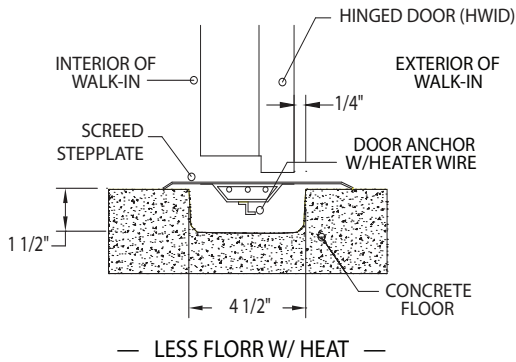

Floor: The Floor step plate can be made for NSF floors or standard floors (without the NSF radius). They are installed by fastening to the door heater channel and will have a 90 degree flange that will partially cover the exterior of the floor panel.

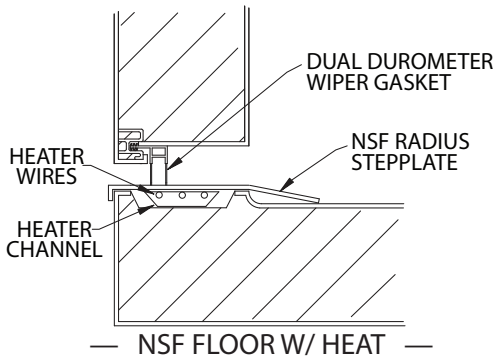

Depression: The Depression step plate will install and function like the Floor Step plate, but the front will not be formed at 90 degrees but will be straight so it can cover the door threshold and bridge over to the building floor. The condition of the building floor depression and the Bally floor panel must be at an even level at the door location.

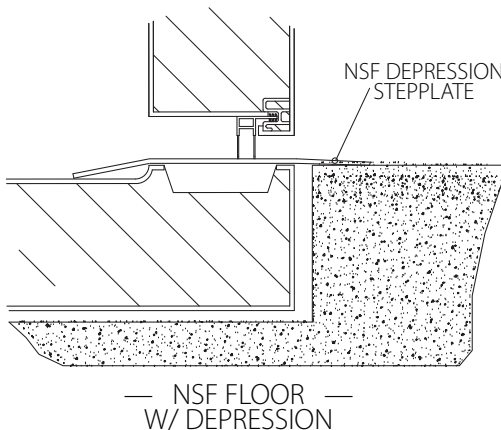

Partition with Floor: The Partition stepplate is designed to cover the threshold and extend through both compartments with radius edges.

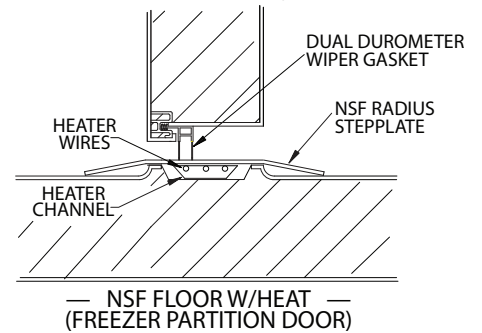

Floor with Tile: The stepplate is designed to cover the raised heater channel and provide a flush transition from walk-in floor to exterior tile.

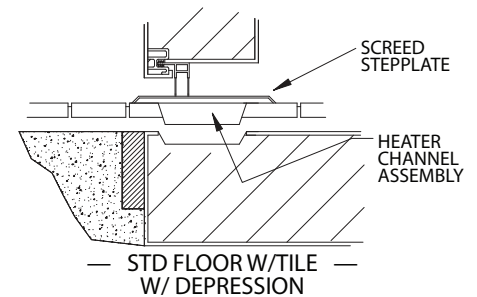

Interior Ramp: The stepplate is designed to cover the threshold which is angled as the door panel is flush with the building floor.

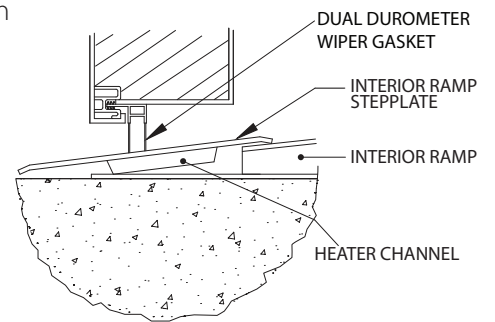

Exterior Ramp: The ramp stepplate is designed to cover the threshold and has a hook on the exterior to fasten the exterior ramp.

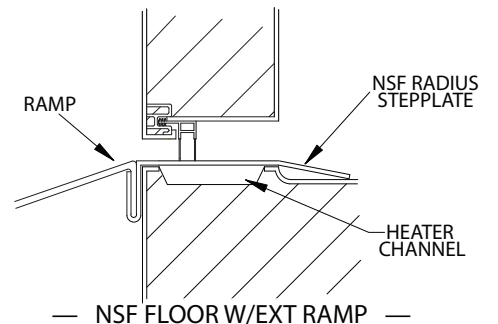

NOTES:

3

FLOOR CONSTRUCTION

GENERAL INFORMATION

Bally can provide design recommendations for many kinds of floor construction. For most installations we recommend Bally floor panels on a properly-prepared base or built-in insulated floors.

An engineer familiar with the circumstances of the individual installation is responsible for the review and approval of all plans because requirements vary widely with individual site conditions and local construction regulations.

INSULATION THICKNESS FOR BUILT-IN FLOORS

When temperatures within the Walk-In or Refrigerated Building are:

- Above 32°F (0°C): one layer of 2" thick sheet urethane required if Cooler is not on ground floor. *Recommended in all other Less Floor applications.*
- Below 32°F (0°C): two layers of 2½" thick urethane (At least R-28 minimum as required by EISA 2007).

In either case, joints must be staggered when urethane is incorporated with Bally built-in insulated floors.

MAXIMUM LOADS ON BALLY FLOOR PANELS

Bally floor panels are designed to withstand uniformly distributed stationary floor loads up to 600 pounds per square foot (psf). Whenever loads exceed these weights, Bally will review and recommend the appropriate solution for the load. Whenever carts are used Bally recommends the use of Diamond Tread overlays or thick-set quarry tile. Reinforced floors with internal 'I' Beam support and 3/16" Diamond Tread overlay are also available for higher rolling weight requirements.

Section View of Stepplate Cutout:

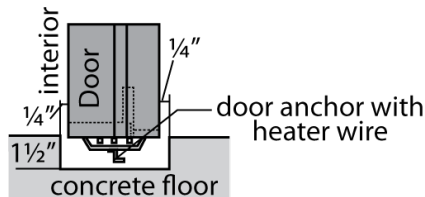

Perspective View of Stepplate Cutout

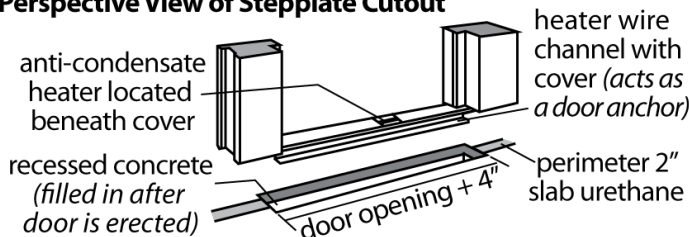

Detail of Perimeter Insulation at Door Openings

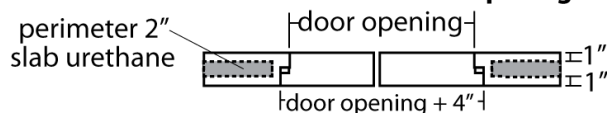

NSF CERTIFIED FLOOR

With Floor

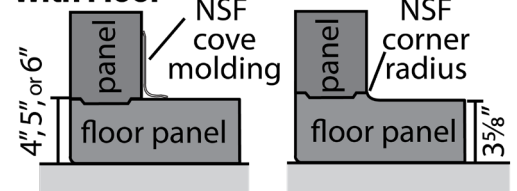

Less Floor (Indoor Only)

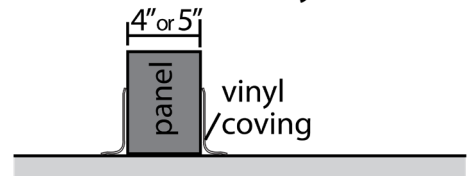

Indoor or Outdoor

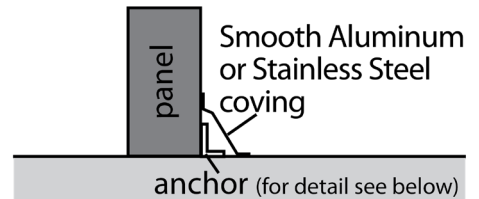

Section View

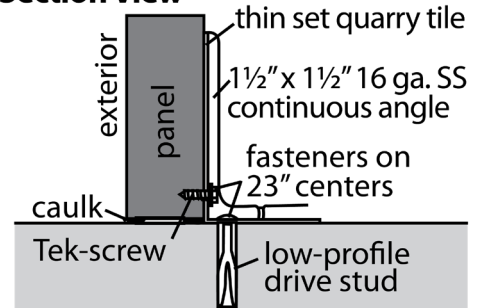

VERTICAL PANEL ANCHORING

Section View

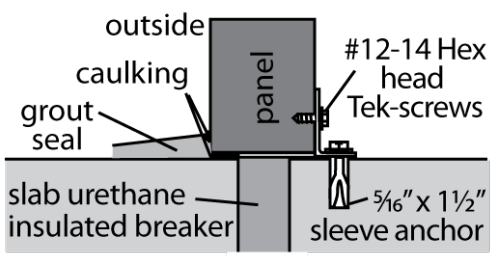

Front View

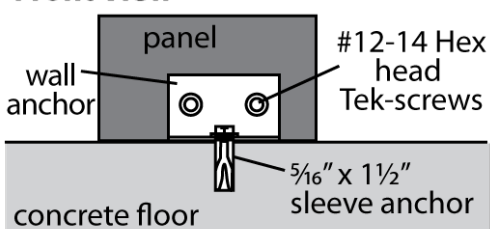

FLOORS

Additional under-floor heating and venting may be required to prevent frost heaving of the floor depending on the size, temperature of application, and location of the structure. *(Dimensions shown are for 4" panels; if 5" or 6" panels are used, adapt drawings accordingly by adding 1" to inside of wall thickness.)*

An engineer familiar with the circumstances of the individual installation is responsible for the review and approval of all plans because requirements vary widely with individual site conditions and local construction regulations.

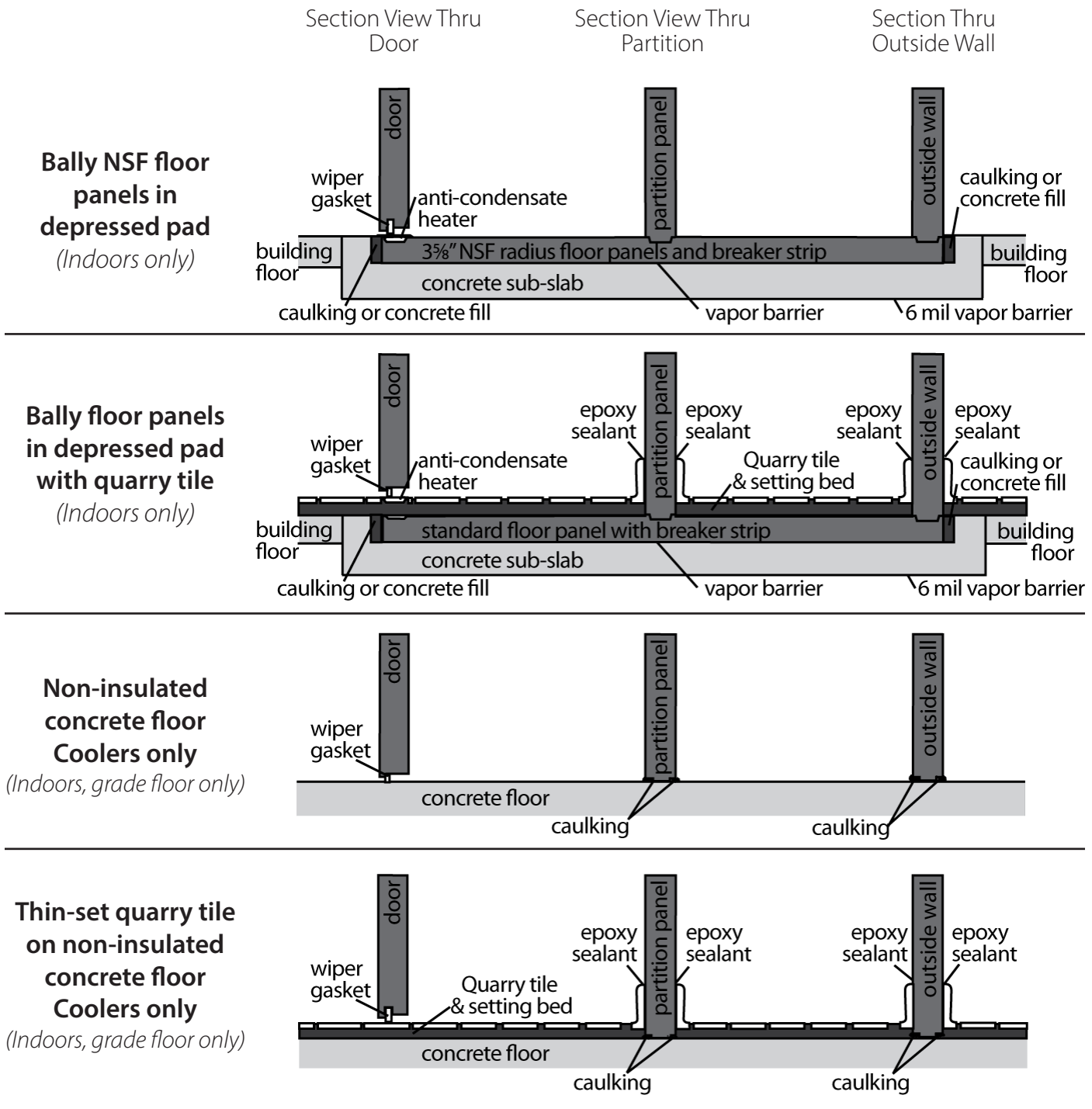

FLOORS

Additional under-floor heating and venting may be required to prevent frost heaving of the floor depending on the size, temperature of application, and location of the structure. *(Dimensions shown are for 4" panels; if 5" or 6" panels are used, adapt drawings accordingly by adding 1" to inside of wall thickness.)*

An engineer familiar with the circumstances of the individual installation is responsible for the review and approval of all plans because requirements vary widely with individual site conditions and local construction regulations.

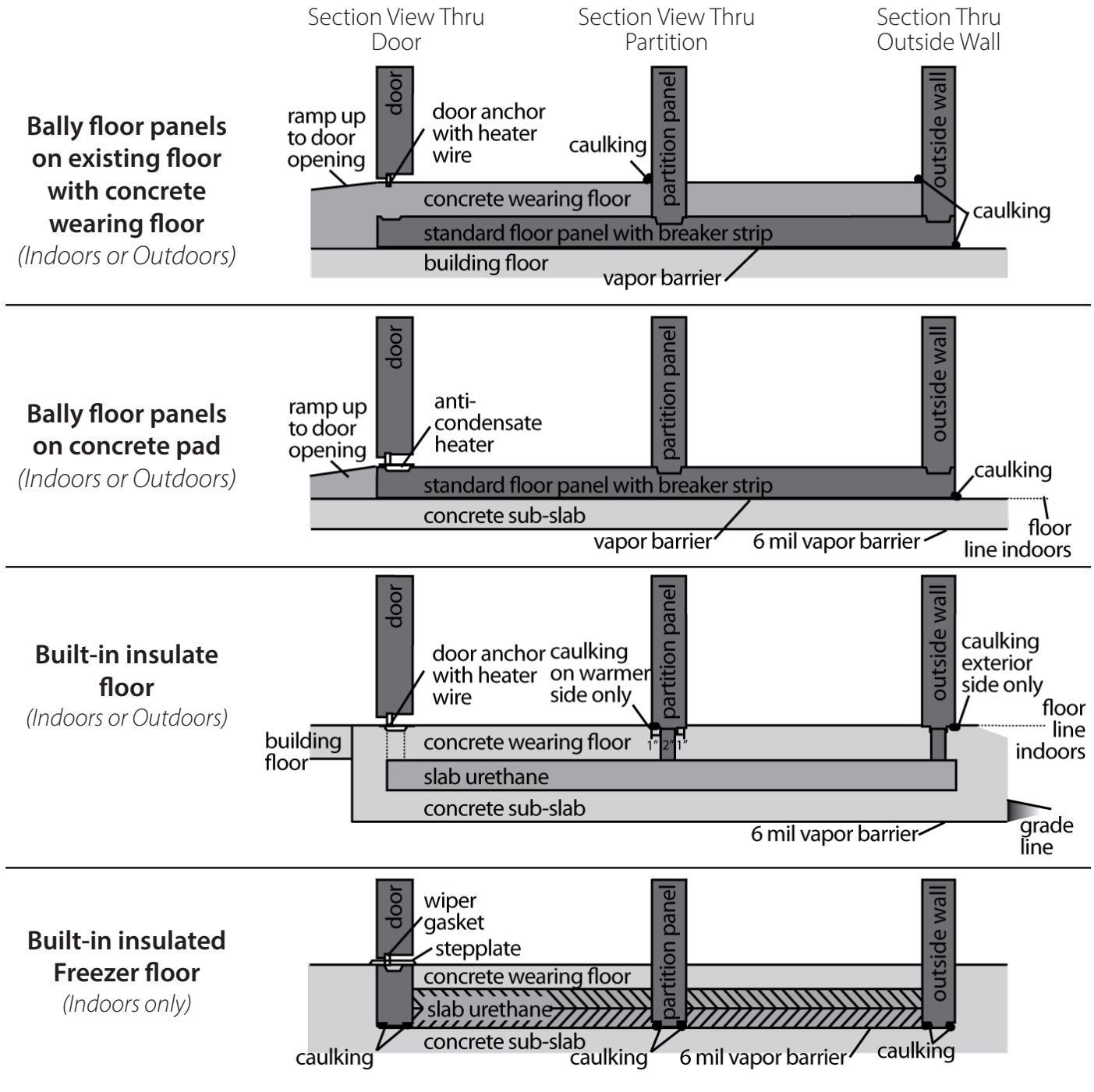

FLOORS

Walk-Ins or Refrigerated Buildings operating at or below 32°F (0°C) must be equipped with under-floor heating or ventilation to prevent ground water from freezing and heaving the floor. Less-floor Freezers require an insulated concrete pad (*by others*), and a 2" thermal breaker under vertical panels to prevent temperature transfer. If installation is outdoors, footings and piers must extend below frost line.

Bally recommends perforated drain and vent piping (*on 6' centers*) with gravel fill when:

- Walk-Ins are located in high water table areas. Keeps the slab dry by serving as air vents and draining excess water.
- Freezers or Cooler/Freezer combinations exceed 225ft² in floor area. Prevents ice build-up by providing warm-air passage through the floor when the ambient temperature is above the ground temperature.

* **Slab urethane sheets (stagger all joints):** Install multiple layers with vapor barrier. R-Value of slab insulation types will vary. An insulation thickness equal to (*or greater than*) R-28 is required. It is the responsibility of the installing contractor to meet the requirements for EISA 2007.

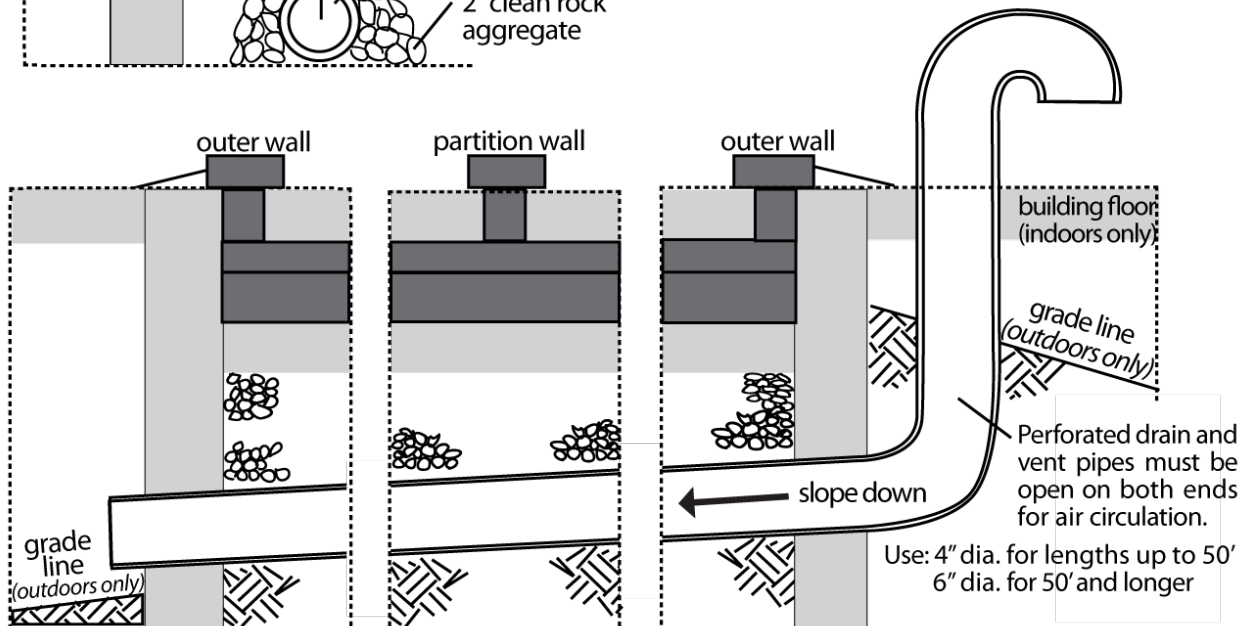
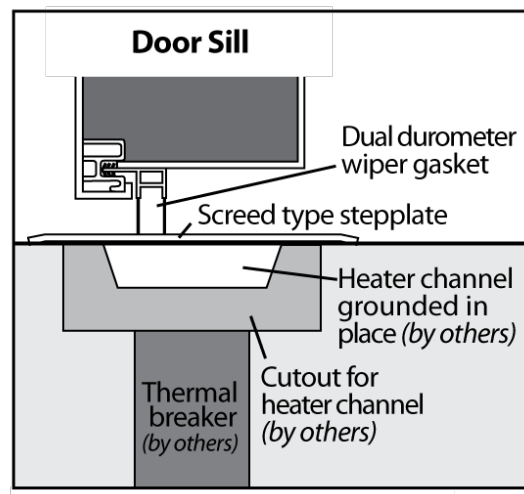
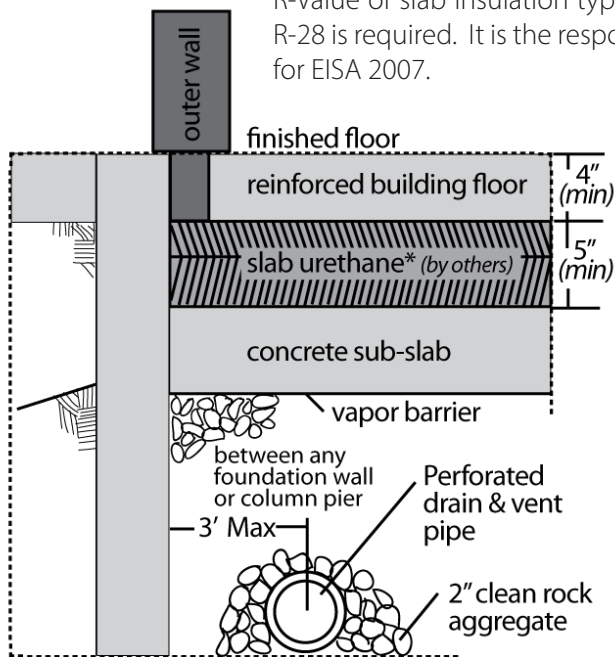

Low end of perforated drain/vent pipe must allow removal of any accumulation of water under the floor and low end flow of cold air from pipe. If grade line is above pipe, a drainage trench or sump and exhaust fan must be provided.

If Walk-In is installed adjacent to an existing structure and vent above ground level is not possible, high end of vent pipe must extend into and above floor line of existing structure.

4

ACCESSORIES

PARTITIONS

Bally's partition panels allow the creation of compartments within a Walk-In. Constructed like our standard wall panels, partition panels are fast and easy to install. Floor, ceiling and wall panels abutting the partitions contain built-in breaker strips, minimizing conductivity between compartments, and eliminating moisture or frost at partition joints. Bally recommends caulking all partition walls, ceilings, and floors when the compartments are a Cooler/Freezer combination.

To gain full advantage of partition breaker strips, ceiling and floor panels should run in the same direction as the partitions. Standard partitions are centered on 23" or 46" wall panels making it possible to locate partitions at distances in multiples of 5¾" from either end. Partitions may also be installed at right angles to other partition panels to form rooms.

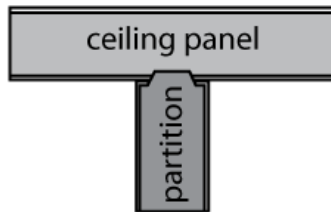
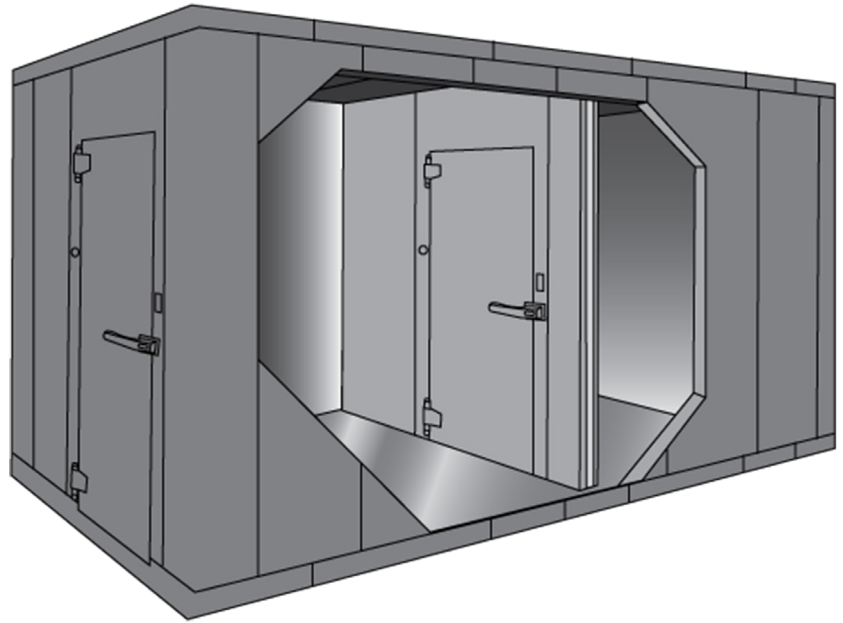

SECTION THRU PARTITION AND CEILING PANEL

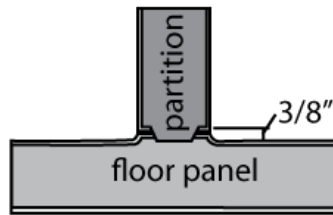

SECTION THRU PARTITION AND FLOOR PANEL

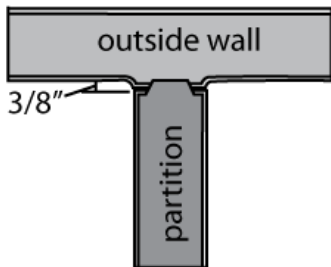

SECTION THRU PARTITION AND WALL PANEL

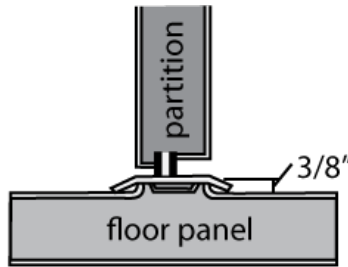

SECTION THRU PARTITION DOOR AND FLOOR

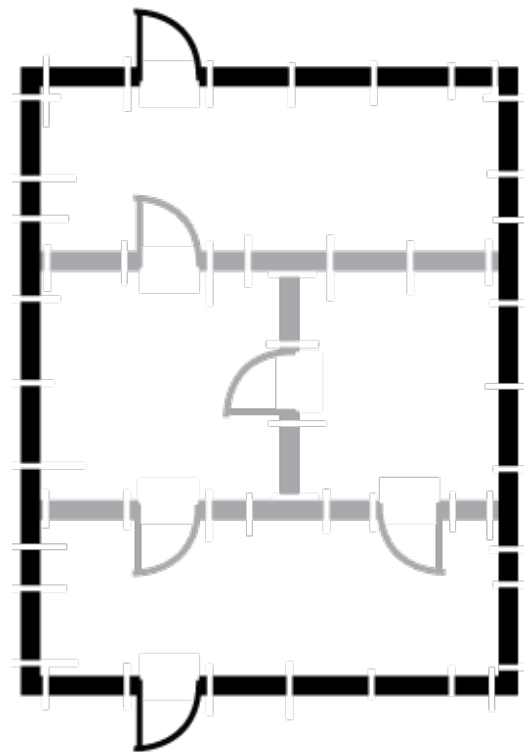

Example of partition walls within a Walk-In.

ACCESSORIES

ADJUSTABLE CANTILEVER SHELVING

Designed specifically for Walk-Ins, Bally's cantilever shelving is adjustable, fast and easy to install or relocate. Cantilever construction provides maximum storage capacity, accessibility and cleanliness.

1. Stainless steel top anchors are held firmly in place by zinc-plated steel sheet metal screws.
2. Heavy-duty extruded aluminum wall standards are attached to panels with zinc-plated steel sheet metal screws.
3. Shelves are positioned over nylon projections and finished with closure caps. Lengths: 36", 48" and 60". Widths: 14" and 21". (*Custom sizes available.*)
4. Two stainless steel support brackets per shelf support product loads.
5. Malleable iron clamps permit fast, easy shelf adjustment. Each clamp is secured by a single 3/8" plated nut and bolt.
6. Wire shelves allow maximum air circulation; raised wire edges keep stored product in place. *Chrome, epoxy, or stainless steel finish.*
7. Elimination of front supports creates easy accessibility.

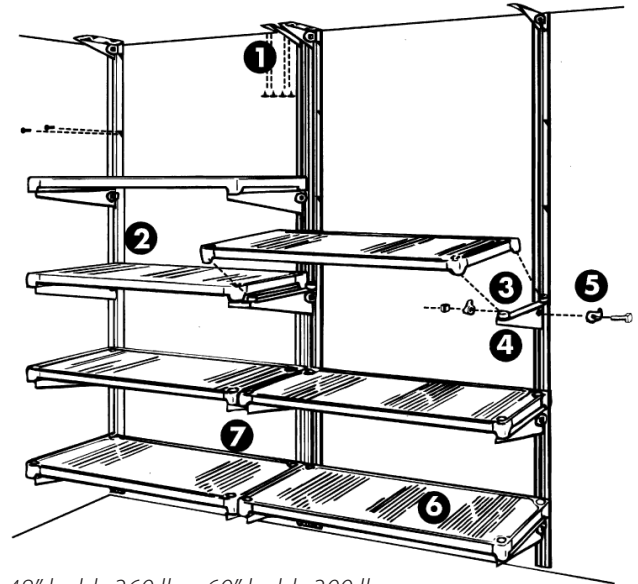

Maximum support capacities (per lengths shown): 36" holds 465 lbs.; 48" holds 360 lbs.; 60" holds 300 lbs.

FREESTANDING WIRE SHELVING

The open-wire design of Bally's heavy-gauge freestanding shelving permits outstanding air circulation. Bally wire shelving provides excellent accessibility, strength, and long-term resistance to corrosion. Shelves may be provided with casters.

1. Open-wire design minimizes dust accumulation, allows for greater circulation of air, and excellent visibility.
2. Versatile construction makes it easy to re-configure shelving.
3. Shelves have rolled, circular grooves lengthwise at 1" intervals. Tapered openings in the shelf corners slide over plastic tapered split sleeves that snap together; providing a positive lock. Shelves are assembled without using special tools.
4. Shelf ribs run front to back, making the product easy to slide.
5. Shelves can be loaded or unloaded easily from all sides.
6. Finishes: *Chrome, Stainless, Epoxy, Flat & Louvered stainless.*
7. Bolt levelers on the feet ensure level shelving.

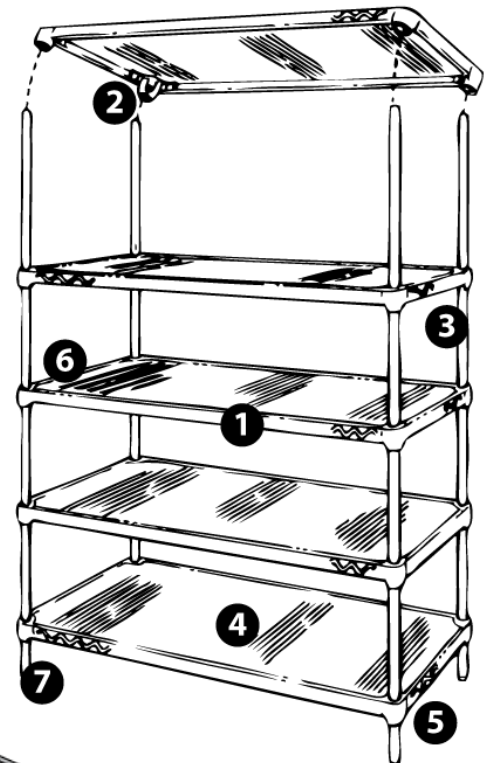

JOINING SHELVES

Continuous freestanding stationary shelving is more economical when one set of posts is eliminated when joining shelves. We use a simple 'S' hook to join shelves and then close post holes with a "press-in" cap.

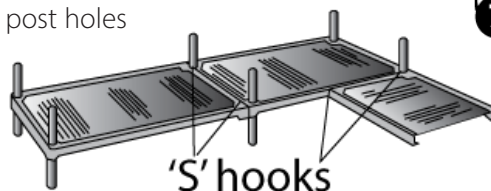

ACCESSORIES

RUB RAILS

For wall protection in heavy use areas, choose rub rails, in single rows or pairs at any height. *Smooth aluminum or stainless steel finishes.*

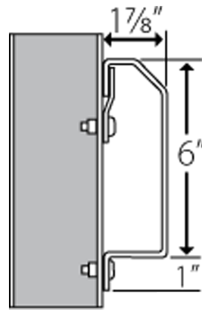

BUMPER GUARDS

Vinyl bumper guards can be installed where lighter wall impacts are expected. The guards are specially developed to be non-marking and highly resistant to impact and abrasion.



COMPACT FLORESCENT & LED VAPORPROOF LIGHTS

Vaporproof lights (*one is provided standard with each door section*) are constructed with cast aluminum bodies, porcelain sockets and Lexan globes.



TEMPERATURE ALARMS

Protect stored goods with temperature alarms that use visual signals and sounds when temperatures rise above set limits. Bally offers several types, including digital and electronic varieties.



PRESSURE RELIEF PORTS

Pressure relief ports allow air pressure inside the building to equalize with air pressure on the outside. The difference in pressure results from temperature changes that occur immediately following coil defrost, or opening the entrance door. Without the port, wall or ceiling panels could be seriously damaged. *(Required on all Freezer applications.)*

Walk-In Freezers less than 400ft²



Walk-In Freezers larger than 400ft²

FLUORESCENT & LED LIGHTS

These fixtures provide diffused fluorescent or LED light, and remain protected from moisture and breakage to temperatures as low as -20°F (-29°C). The high-impact plastic housings are molded with plain surfaces that shed dirt and water.



FLOOR AND CEILING EDGE CAPS

When an exterior front or side is finished with a metal different than the rest of the Walk-In, the exposed edges of the floor and ceiling panels may require edge caps.

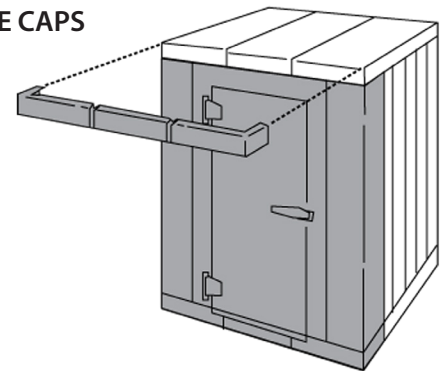

4" FLOOR SCREEDS

Multi-compartment Walk-Ins without floors may be supplied with extended length panels or insulated screeds of the same height as the floor they replace. Screeds can be used in medium or low temperature applications.

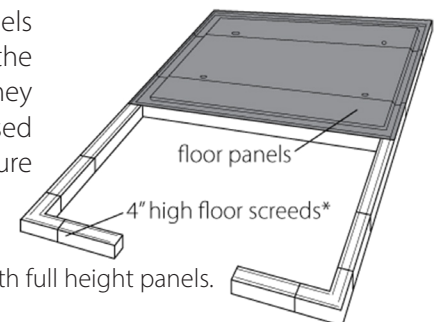

*Or extended length full height panels.

ACCESSORIES

ENTRANCE DOOR RAMPS

Door ramps are configured for Walk-Ins where floor panels cannot be recessed. Standard ramps for 4" floor panels are 1:8 slope (*Maximum stationary load is 650 lbs. Ramps that meet the Americans with Disabilities Act are available.*)

INTERIOR RAMPS

Interior ramps are made by a metal skin (*same as the floor finish*) mounted on a high-density foam base, with Safety Walk traction strips. The ramp requires custom door and floor panels and a predetermined door location.

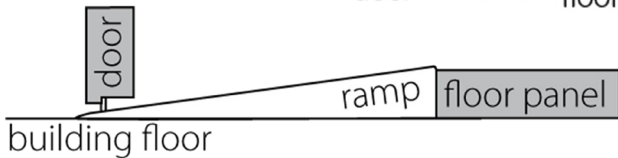
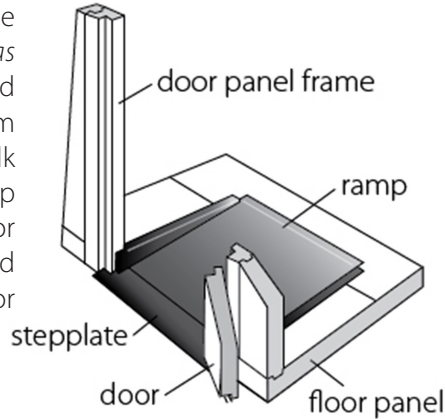

EXTERIOR RAMPS

Exterior ramps are made of reinforced Aluminum Tread plate. The ramp is hooked onto a special flanged stepplate that is mounted on the threshold and secured to the Walk-In.

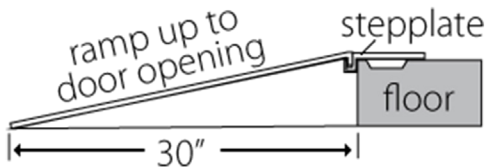
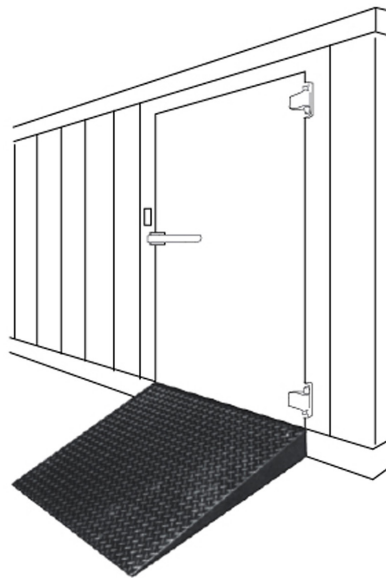

MEMBRANE & BUILT-UP TYPE ROOFS

A roof is required on all outdoor installations. For Walk-Ins up to 34'7" x 34'7" a membrane roof is most economical. For buildings wider than 34'7", Bally recommends a built-up roof. Bally reviews factors including existing building locations, snow loads, and wind factors to determine the correct roof for the specific installation.

Membrane (Basic Walk-In)

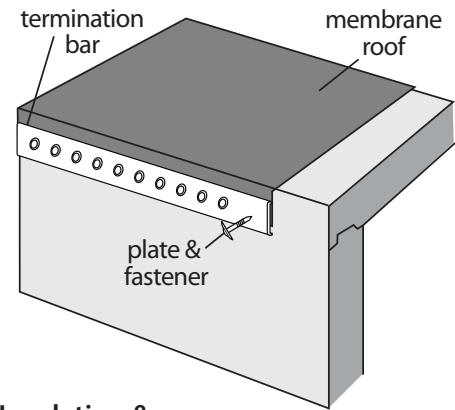

Tapered Insulation & Gutter

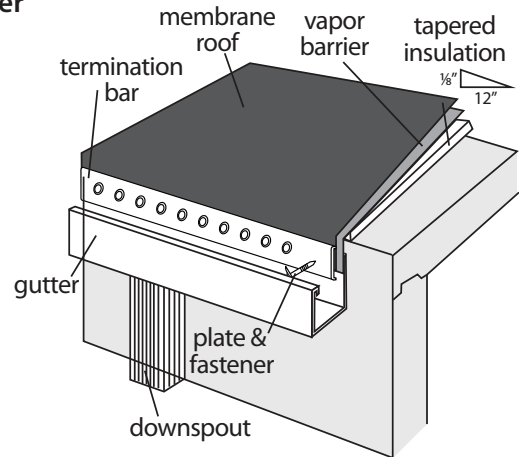

Built-up

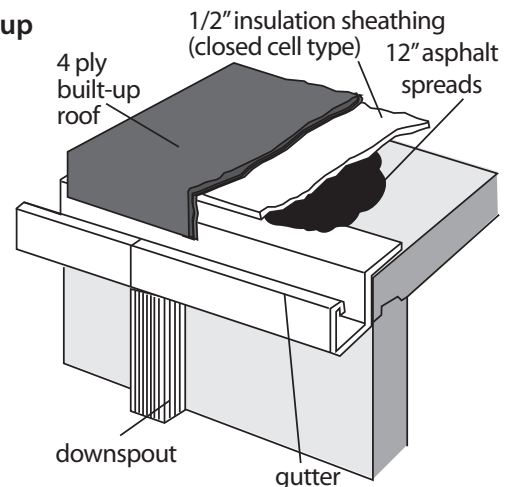

5

NORTHWIND™ BLAST CHILLER

Federal and state codes for food-service safety require that potentially hazardous foods be chilled through the Danger Zone (140°F to 40°F) in four hours or less. Ordinary Walk-Ins cannot meet these rapid chilling requirements, but Bally's Northwind Blast Chillers offer total blast chilling reliability in sizes to meet the needs of any kitchen.

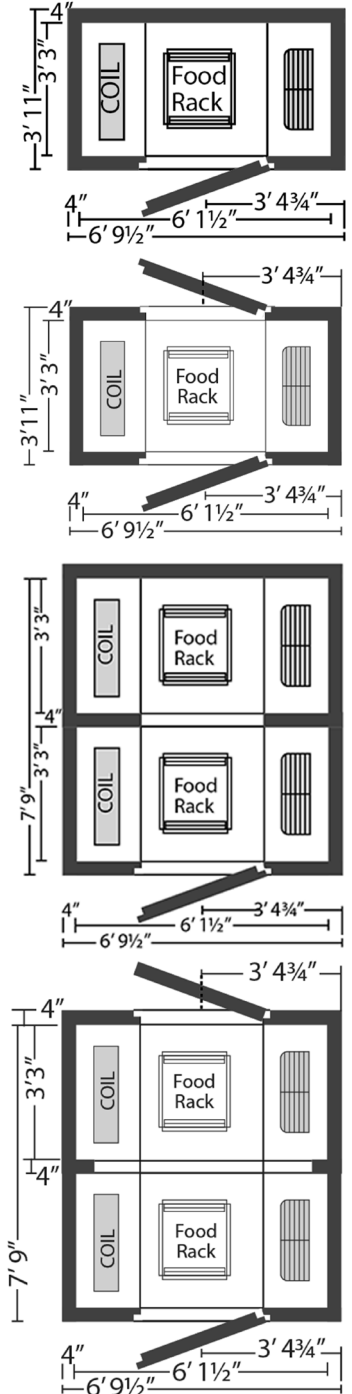
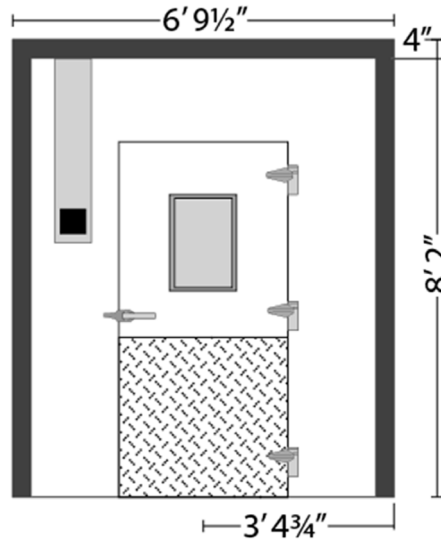

NORTHWIND BLAST CHILLER SPECIFICATIONS

Chilling Capabilities	Foods are cooled through the Danger Zone (140°F and 40°F) in 60-120 minutes (<i>Some in considerably less time</i>). Chill speed depends on: product density, moisture content, specific heat and containerization. Time/temperature chill-down meets all FDA and state regulations.
Finishes	Stainless Steel (<i>standard</i>), Smooth White Aluminum, Smooth White Galvanized steel, Stucco-Embossed White galvanized steel, Stucco-Embossed Stainless steel, Stucco-Embossed Galvalume steel, Stucco-Embossed Aluminum
Construction	4" thick panels of foamed-in-place, non-ozone depleting urethane installation sandwiched between metal skins.
Refrigeration Systems	Bally's laminar airflow system uses a 3.5hp, R-404, Air- or Water-cooled pre-assembled remote system available in 208/3-phase or 460/3-phase. Dual-cycle operating temperatures and a streamline air flow design chill without freezing. 5°F deep-chill converts to a 37°F storage mode.
Doors	Construction matches panels. 36" x 78" opening is compliant with the Federal Americans with Disabilities Act.
Systems Wiring	Electrical systems are easily connected between the control panel and internal operating system by color-coded plug-ins.
Racks	Most standard kitchen racks, including Combination Oven racks, fit.
Approvals	Panels and electrical components are EISA 2007 Compliant, FM Approved, NSF Certified, and UL Listed.
Packages	Multi-probe: Removable probes, with quick-disconnect cables for easy cleaning, are monitored by exterior-mounted digital temperature readouts and alarms for each of the probe positions. Security for Correctional Facilities: Key-lock control switches, fixed probes with stainless steel sheathing, and tamper-proof hardware screws.

NORTHWIND™ BLAST CHILLER

ELECTRICAL DATA

Model	Max Project Load Lbs./Cycle	Exterior Cabinet Dimensions			Door Opening		Volts	Phase	Hz	Total Amps	
		Width	Depth	Height	Width	Height				MCA	MOP
500	250	81½"	47"	98"	36"	78"	120/208-230	1	60	20	30
1000	500	81½"	93"	98"	36"	78"	120/208-230	1	60	27	30

CONDENSING UNIT DATA

	Size	*Req. NET BTU/hr.	Water GPM	Model	Voltage	RLA	LRA	AMPS	MCA±	MOP±
Air Cooled	500	22,800	n/a	BEZA035M8	208-230/3/60	15.5	93	17.6	21.5	35
	500	22,800	n/a	BEZA035M8	460/3/60	6.9	48	8.2	9.7	15
	1000	49,400	n/a	BEZA076M8	208-230/3/60	39.3	225	43.5	53.3	90
	1000	49,400	n/a	BEZA076M8	460/3/60	17.3	114	19.5	23.8	40
Water Cooled	500	22,300	3.5	BXZA035H8	208-230/3/60	13.9	88	15.5	19.4	30
	500	22,300	3.5	BXZA035H8	460/3/60	6.9	48	6.9	8.6	15
	1000	48,200	17.6	BW750M8	208-230/3/60	31.6	169	31.6	39.5	70
	1000	48,200	17.6	BW750M8	460/3/60	13.8	85	13.8	17.2	30

Time and temperature relationships are critical to the growth and spread of contamination, contributing to the loss of quality and safety in foods. The Northwind was created to offer greater heat removal than a Walk-In and utilize high-velocity convected air directed through the product to promote fast, even cooling of foods. The standard recommendation for rapid cooling of food is 2" of product depth and at most four hours in the Danger Zone.

1. Cooling Times in Standard Walk-ins

Food Product	Hours to Cool in Pan		
	2" Deep	4" Deep	6" Deep
Beef Stew	12	16	22
Broccoli	7	9.5	14
Chicken and Turkey a la King	10	14	22
Gravy	11	14	21
Lasagna	11	17	21
Mashed Potatoes	12	16	22
Peas	6	9	13
Sliced Beef and Gravy	10	13	23
Swiss Steak with Tomato Sauce	13	17	20

Product cooled from 140°F to 40°F in a 38°F holding refrigerator.

2. Bacteria Growth Rate Chart

Organisms	Generation Time (min. at 98.6°F)
Escherichia coli	17 in broth (12.5 in milk)
Salmonella typhi	23.5 in broth
Staphylococcus aureus	27-30 in broth
Streptococcus lactis	48 in broth (26 in milk)

Weiser, Mountney, and Gould, *Practical Food Microbiology and Technology* Table 38.

*Capacity of unit based on 10°F SST with R448A refrigerant.

3. Product Chilling Rate

Product Load: 200 lbs. beef stew
in forty 12" x 10" x 2½" pans.

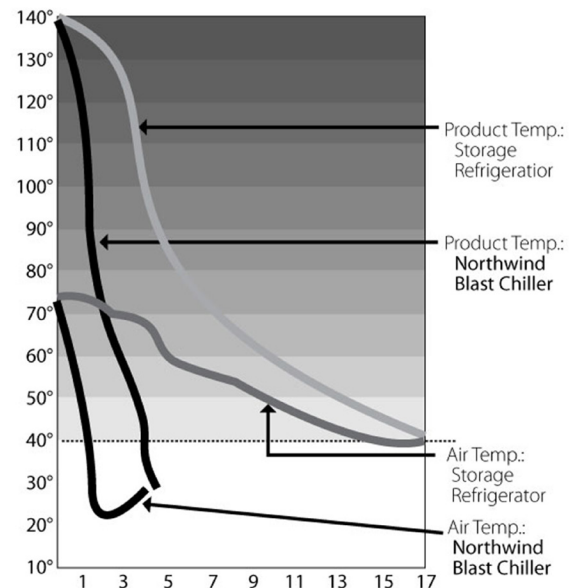

References:

- Sandra J. Ley, R.D. *Foodservice Refrigeration* CBI Publishing Co., Inc. (Boston: 1980)
- "Cooling Times," Table 2.2, *ibid.*, p. 24.
 - "Bacteria Growth Rate Chart," Table 2.1, *ibid.*, p. 24.
 - "Product Chilling Rate," Table 3.1, *ibid.*, p.50.

6

REFRIGERATED BUILDINGS

Bally Refrigerated Buildings and Warehouses deliver inherent panel strength, versatility, and a comprehensive design process.

REFRIGERATED BUILDINGS: DESIGN FEATURES

1. Bally pre-engineered panels. *See Section 1.*
2. Sliding entrance door. *See Section 2.*
3. Hinged self-closing entrance door. *See Section 2.*
4. Anti-condensate heaters concealed beneath doorjamb s prevent frost formation.
5. Partition wall. *See Section 4.*
6. For installations requiring built-in floors, slab urethane is recommended.
7. Columns support load-bearing beams.
8. Lateral bracing.
9. Type and amount of steel support varies according to site conditions and local construction regulations. Review and approval of steel is the responsibility of an engineer familiar with the installation. All buildings must account for local wind and snow conditions.
10. Built-up insulated roof by others. Or up to 34'7" x 34'7" membrane roof by Bally. *See Section 4.*
11. Remote Refrigeration System: condensing units, blower coils and all necessary controls.
12. Vestibules can be assembled from standard panels.

Requirements vary widely with individual site conditions and local construction regulations. Review and approval of all plans is the responsibility of an engineer familiar with the individual installation.

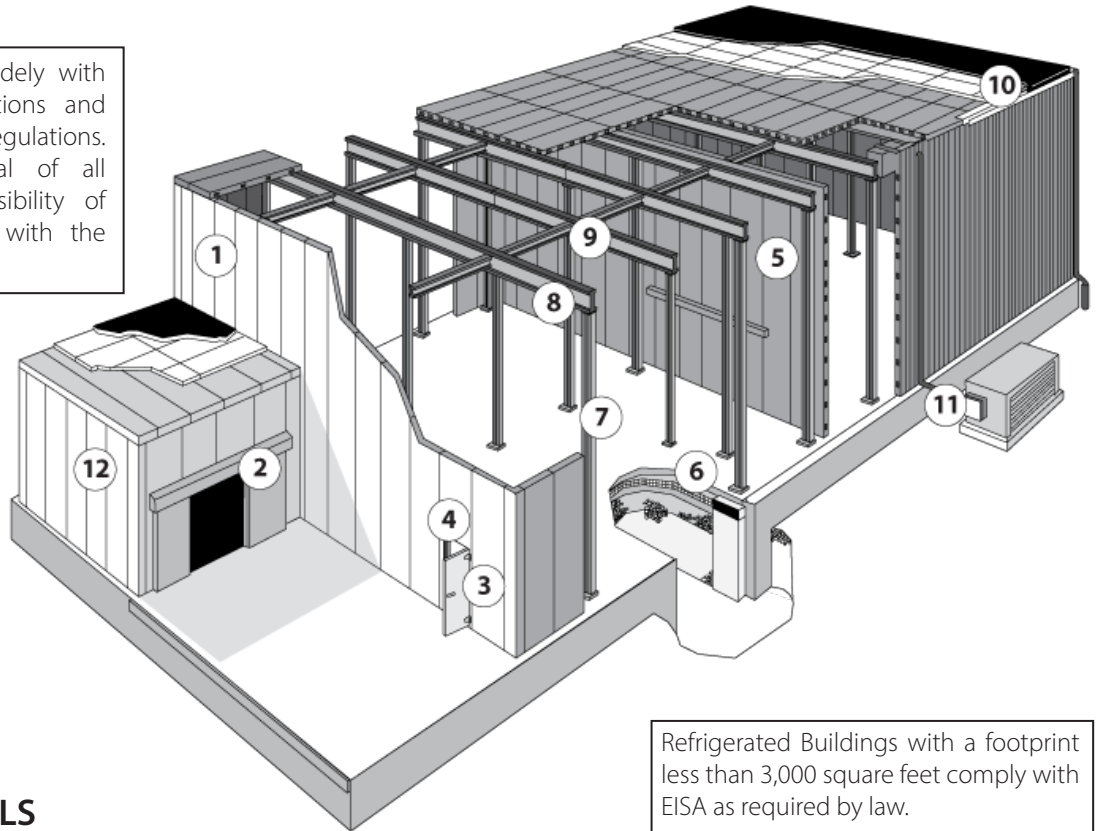

Refrigerated Buildings with a footprint less than 3,000 square feet comply with EISA as required by law.

MULTI-SPAN PANELS

When the width and length of Refrigerated Buildings exceed 18' indoors or 12' outdoors (18' single span reinforced ceiling panels are available for 20 psf snow load areas), multi-span ceiling and floor panels are required.

Dimensions of Ceiling panels:

	End Panels	Center Panels
Length	5'9½", 6'9", 7'8½", 8'8", 9'7½", 10'7", 11'6½"	5'9", 6'8½", 7'8", 8'7½", 9'7", 10'6½", 11'6"
Width	23½"	11½", 23", 34½", 46"
Single panel height	5'10" to 15'4": Embossed Aluminum, Embossed White aluminum, Stainless steel 5'10" to 27'8": Embossed Galvalume Steel, Smooth White Steel, Embossed White Steel	

REFRIGERATED BUILDINGS

TYPICAL BUILDING CONSTRUCTION (Cut away view)

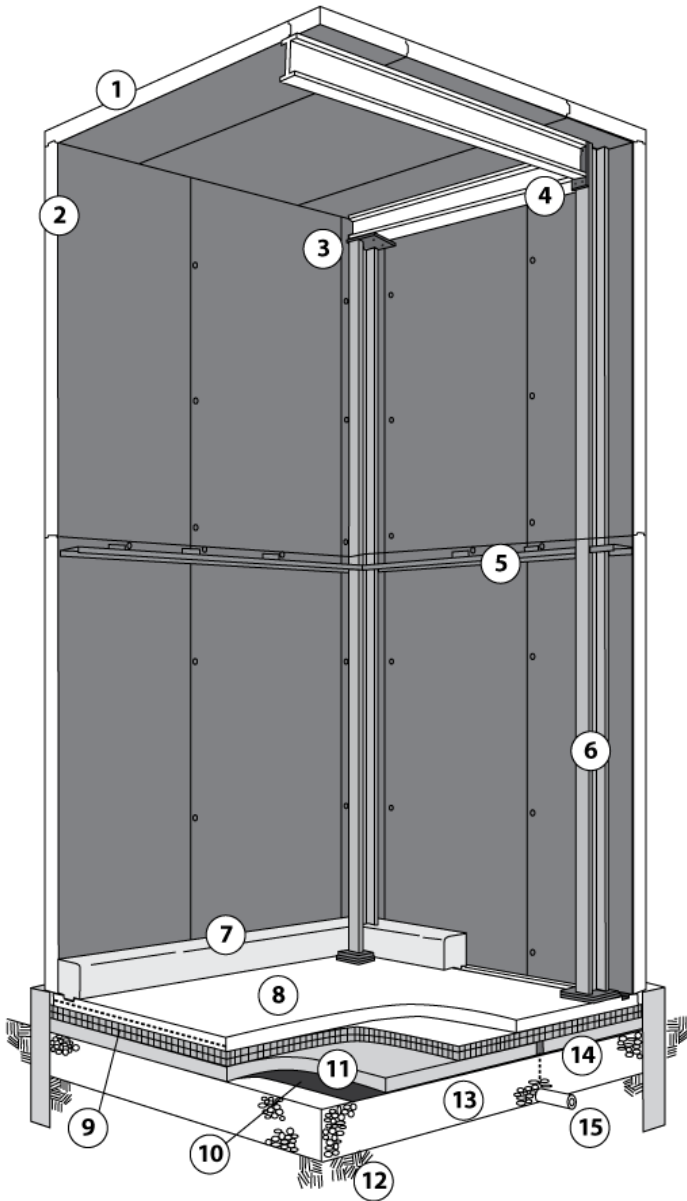

1. Ceiling panels (exterior access holes where steel is required).
2. Vertical panels (single span or multi-tier).
3. I-Beam Support: Pinned Connection
4. I-Beam Support: Moment Connection
5. Horizontal steel girts when required.
6. Supporting columns.
7. Optional concrete-reinforced curb poured after building installation is complete.
8. Reinforced concrete floor. *Thicknesses vary.*
9. Two layers of 2½" thick sheet urethane. (at least R-32 as required by EISA 2007)
10. Watertight seal formed by 6 mil vapor barrier of suitable material. (Sealed joints)
11. Concrete sub-slab, thickness varies according to job site (piers and footings required if installed outdoors).
12. Hard-tamped earth.
13. 2" rock aggregate. Depth determined by local building codes. (Required on Freezers)
14. 1" drain holes for water seepage.
15. 4" or 6" diameter perforated drain and ventilation pipes spaced on 6' centers, running the entire length of the Refrigerated Warehouse floor. See Section 3.

Individual site requirements vary. All floor details must be reviewed by an engineer familiar with the specific installation.

TOTAL ALLOWABLE UNIFORM LOAD (psf)

Allowable load on certain steel skins based on:

1. Skin buckling with a safety factor of 2.25
2. Deflection of L/240 for ceiling panels
3. Deflection of L/180 for vertical panels
4. Core Shear with a safety factor of 3.0

Ceilings	5'10"	6'9½"	7'9"	8'8½"	9'8"	10'7½"	11'7"
	4"	69	57	48	41	36	28
	5"	88	73	62	53	47	36
	6"	107	89	77	66	57	51

Reinforced Ceilings	9'8"	10'7½"	11'7"	12'6½"	13'6"	14'5½"	15'5"	16'4½"	17'4"	
	4"	70	59	50	42	36	31	26	22	20
	5"	102	84	70	60	52	44	38	34	30
	6"	196	150	114	90	72	61	49	42	37

Lateral Load Walls	6'10"	7'10"	8'10"	9'10"	10'10"	11'4"	12'4"	13'4"	14'4"	15'4"	16'4"	17'4"	18'4"	19'4"
	4"	72	60	52	45	39	32	28	25	22	20	18	16	14
	5"	92	78	67	58	51	48	42	37	32	28	25	22	18
	6"	112	95	82	71	63	57	48	41	35	31	27	24	19

REFRIGERATED BUILDINGS

STRUCTURAL SUPPORT

Refrigerated Buildings requiring structural steel must be approved by state or local building authorities. Bally recommendations are based on: dimensions, location, and the building's use. The most common methods of structural support are:

- Vertical Panel Support
- Self-supporting ceilings
- Support from overhead structures
- 'I' Beams
- Back-to-back 'Z' Purlins
- Pallet Rack Support

VERTICAL PANEL SUPPORT

When outdoor Refrigerated Buildings are more than 20' high, vertical panels must be fastened to horizontal steel girts which extend from steel column to steel column.

Panel Height	Dim. A
236"	117 ⁵ / ₈ "
248"	129 ⁵ / ₈ "
260"	
272"	135 ⁵ / ₈ "
284"	147 ⁵ / ₈ "
296"	
308"	159 ⁵ / ₈ "
320"	
332"	171 ⁵ / ₈ "

Cut-away perspective view single-tier panel

Cut-away perspective view multi-tier panel

STRUCTURAL SUPPORT METHOD 1: 'I' Beam Type

Pinned Connections are used for heavy ceiling or snow loads, Moment Connections are used for high wind areas. Ceiling panels are supported by conventional structural steel which may be designed to meet local conditions. Exterior ceiling panel Speed-Lok access holes must be specified for this type of construction.

PINNED CONNECTION SECTION VIEW

MOMENT CONNECTION SECTION VIEW

END PLATE

REFRIGERATED BUILDINGS

STRUCTURAL SUPPORT METHOD 2: Suspended Ceilings - *Indoors Only*

Ceiling panels of Refrigerated Buildings installed indoors can sometimes be supported from overhead structural steel. This provides a column-free interior. *(Existing building steel must be reviewed for adequate support.)*

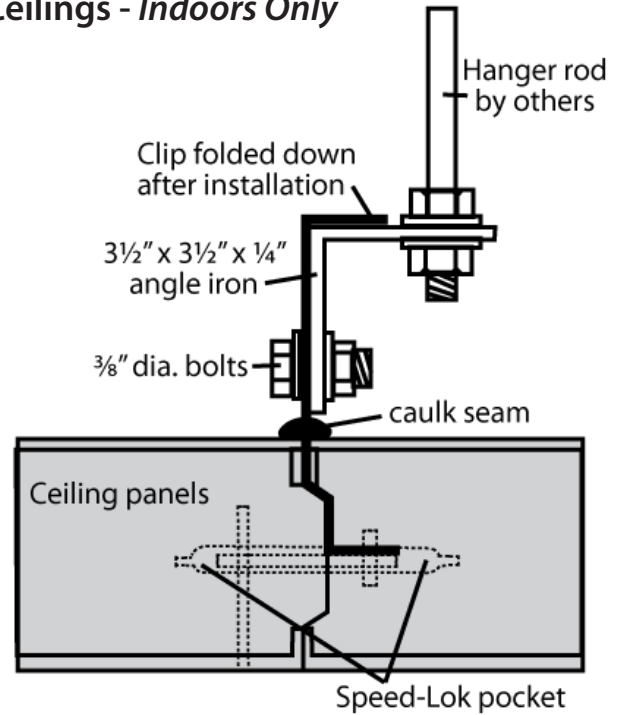
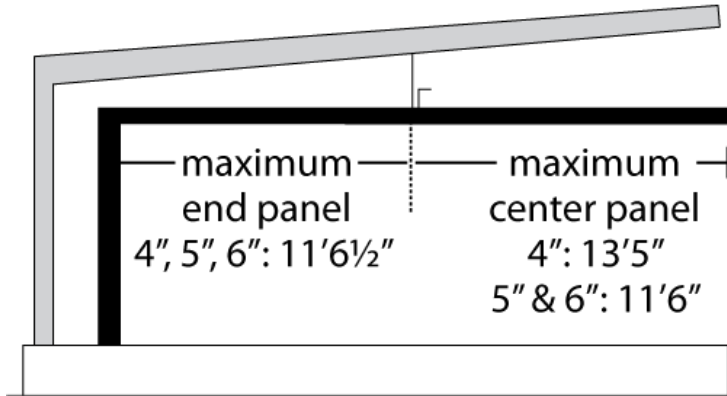

STRUCTURAL SUPPORT METHOD 3: Back-to-back 'Z' Purlins

Ceiling panels are supported by conventional structural steel which may be designed to meet local conditions. Exterior ceiling panel Speed-Lok access holes must be specified for this type of construction.

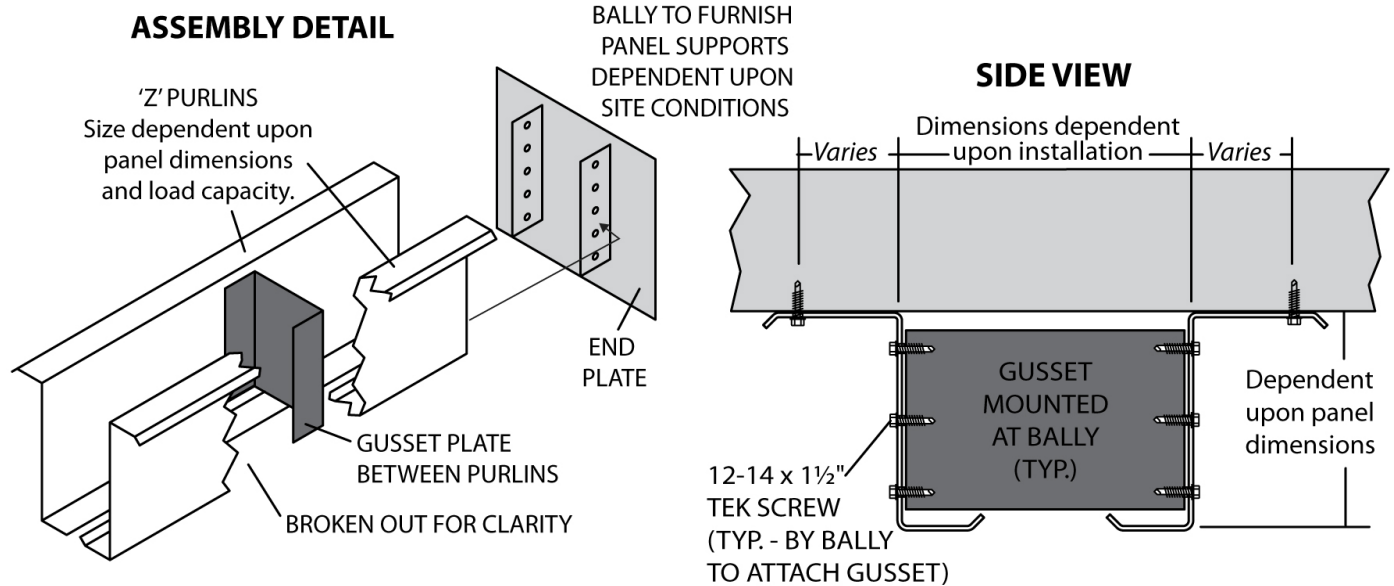

PURLIN ASSEMBLIES TO BE ATTACHED TO END PLATES IN FIELD

Requirements vary widely with individual site conditions and local construction regulations. Review and approval of all plans must be the responsibility of an engineer familiar with the individual installation.

REFRIGERATED BUILDINGS

STRUCTURAL SUPPORT METHOD 4: Self-supporting Ceilings - Indoors Only

Ceiling panels are suspended from channels that are placed over ceiling panel joints by "hangers" spaced every 23". The channels transmit the weight of the ceiling to the wall panels where it is distributed evenly by load-bearing angles. Channels do not support suspended evaporator coils or storage on top of building. During installation temporary inside supports must be provided, and ceiling panel traffic minimized.

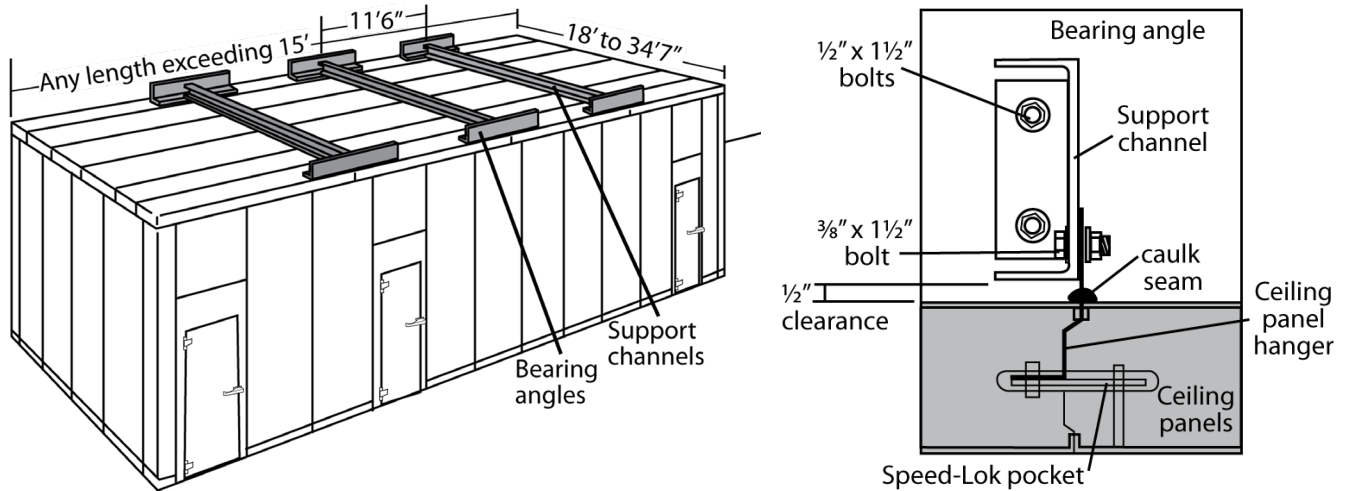

STRUCTURAL SUPPORT METHOD 5: Pallet Rack Support

In an installation where pallet racks are to be installed, Bally can configure the pallet racks to act as a method of structural support allowing for more space and layout options. *Dimensions vary with site requirements.*

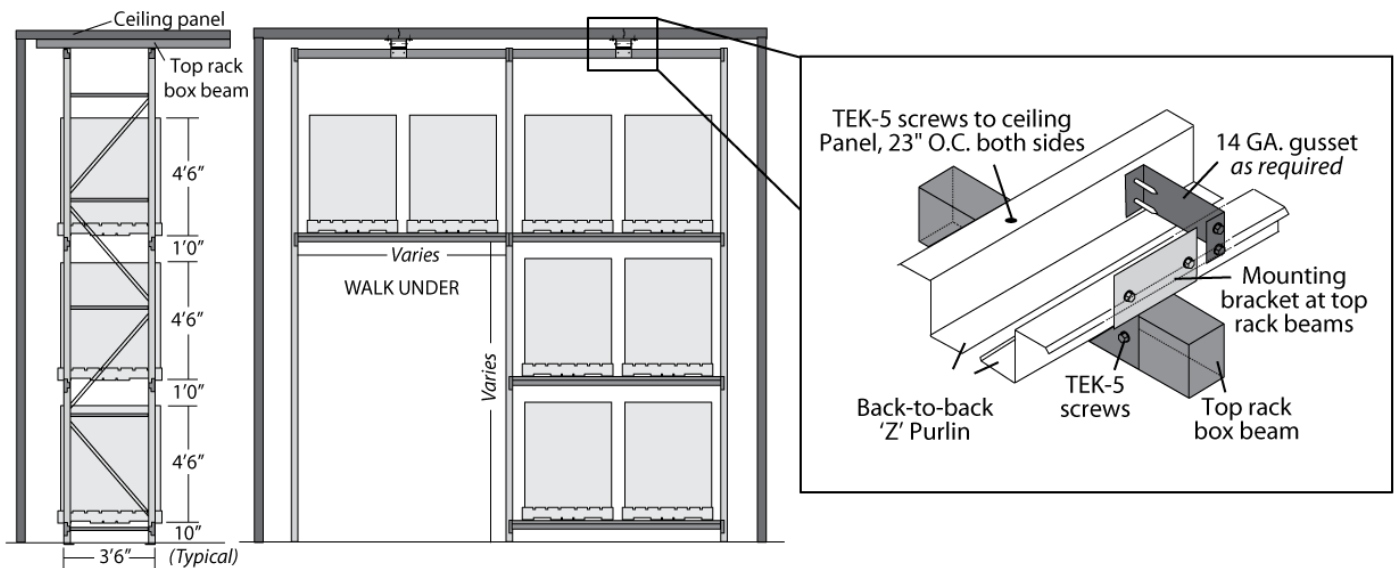

Requirements vary widely with individual site conditions and local construction regulations. Review and approval of all plans must be the responsibility of an engineer familiar with the individual installation.

REFRIGERATED BUILDINGS

Dimensions shown are approximate, specific dimensions will be calculated according to the application.

WAREHOUSES WITH BUILT-IN INSULATION: OUTDOOR INSTALLATIONS

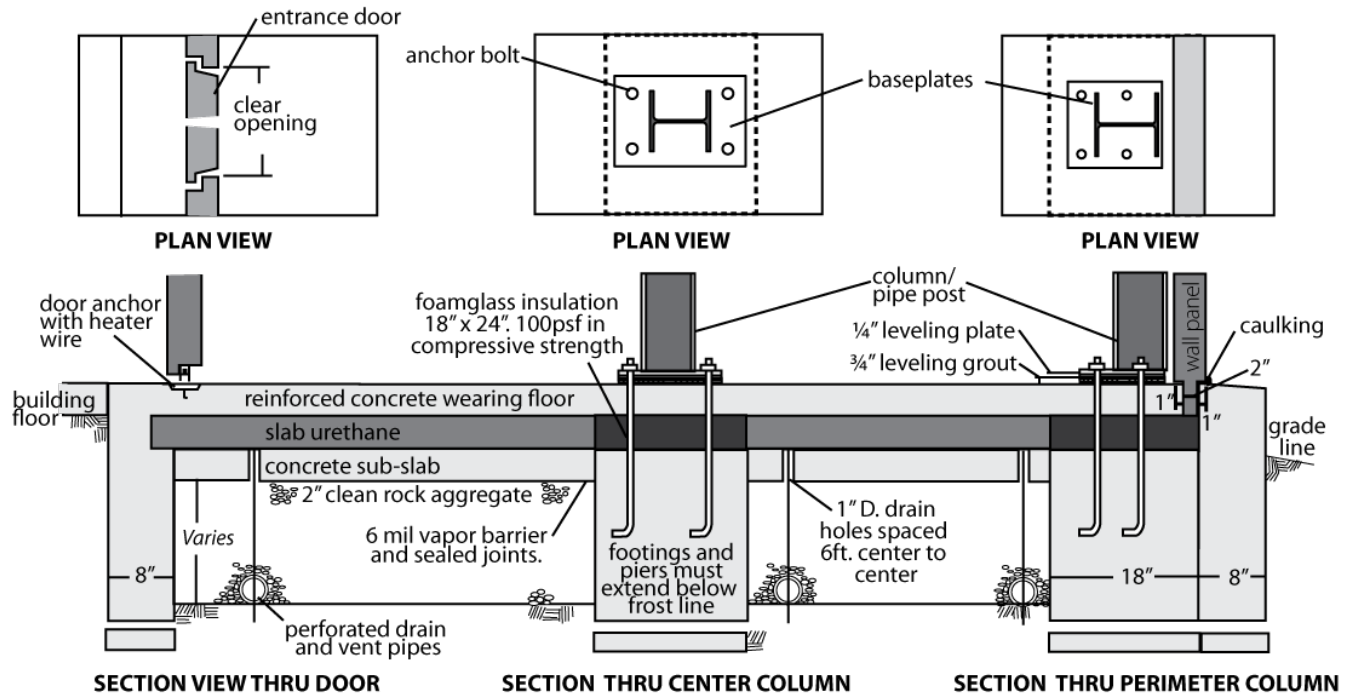

WAREHOUSES WITH BUILT-IN INSULATION: INDOOR INSTALLATIONS

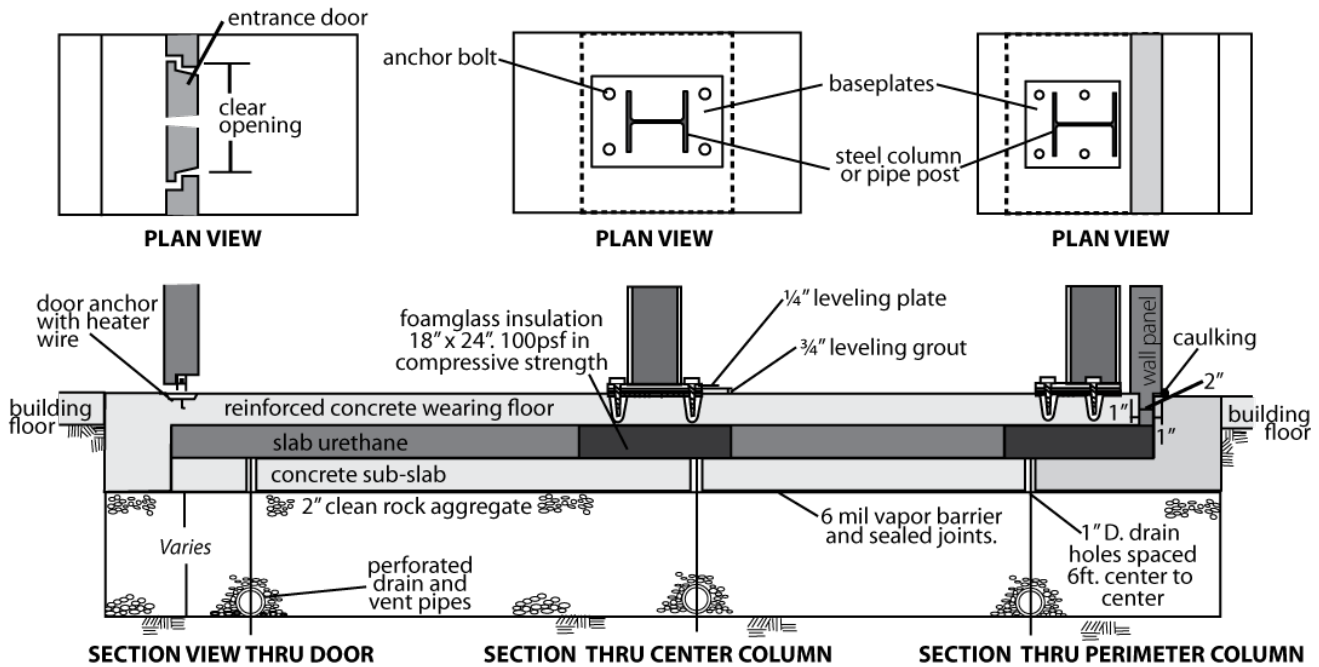

Requirements vary widely with individual site conditions and local construction regulations. Review and approval of all plans must be the responsibility of an engineer familiar with the individual installation.

7

LAYOUT SUGGESTIONS

PROPER SIZE SELECTION AND LAYOUT

Determining Requirements

Capacity:

Determine the amount of space needed within the Walk-In. Typically, 1 cubic foot of storage space per person per meal is needed (*½ cubic foot for frozen foods*).

Proportion:

Consider what proportions of Cooler and Freezer space is needed, and the number of compartments. Many kitchens have separate sections for dairy products, vegetables, baked goods, etc.

Height:

Standard Walk-In heights are 7'6", 8'6", 9'6", 10'6", and 11'6" (*with floor*). For installations in spaces with low ceilings, 6'6" high Walk-Ins are available on special order. See Section 6 for heights available for Refrigerated Buildings.

Floor Area:

Determine the width and length desired. Best use of available space should determine this decision. *Consult a Bally representative to help determine suitable configurations.*

Location:

Walk-Ins may be located inside existing structures or outdoor with a weather roof of some type. Bally recommends and supplies membrane roofs for most applications up to 34'7" x 34'7". Outdoor Walk-Ins must also take into account snow load and wind factors. 5" thick ceiling panels up to 10' long will support a snow load of 40 psf. 5" thick ceiling panels 12' long will support a snow load of 30 psf. Bally supplies optional reinforced ceiling panels. *Consult the Factory for details.*

Locating Doors

With the exception of corners, most Bally panels are made in multiples of 11½" widths. Typically, door panels are interchangeable with vertical panels. Locate doors where they will provide the most convenient access and the most storage space. Standard Doors function in most applications, but Bally does have options when needs dictate.

Off-Set Doors:

Used when the opening in a door panel is off-center by a minimum of 1". The opening must remain a minimum of 4" from the end of the door panel to the exterior side of the door cap opening.

Tight Corner Doors:

Used when space is limited and no other suitable configuration available. Trim is provided for the intersection of the door panel and wall panel, adding a ½".

This example shows a 36" door in a 57½" panel.

Standard Door

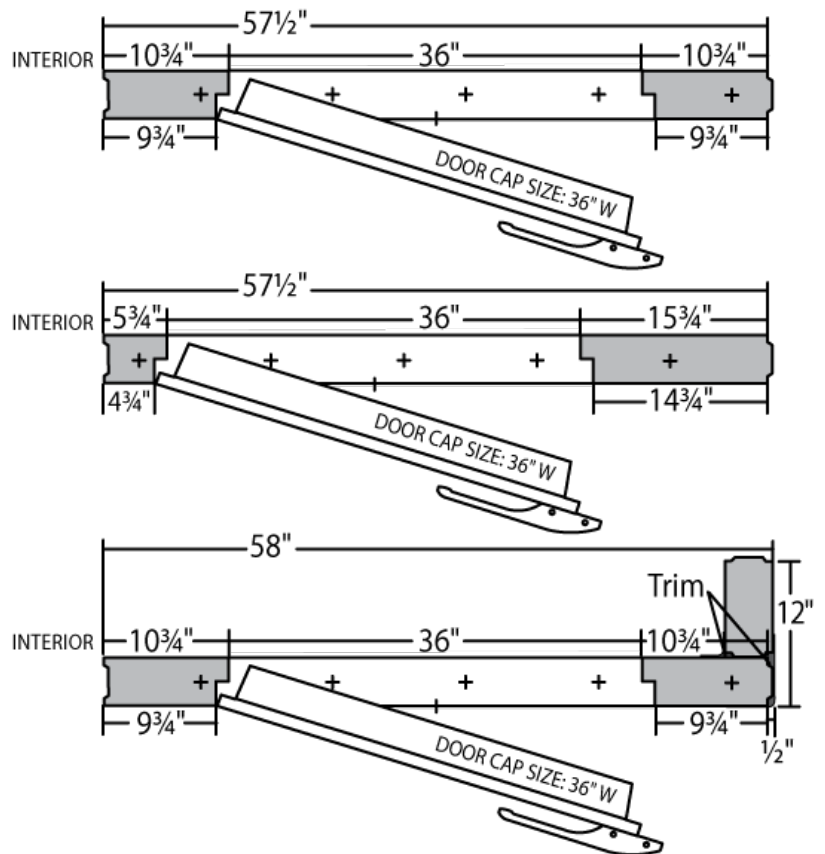

LAYOUT SUGGESTIONS

INSTALLING WALL PANELS

- 1. With floor panels.** This method is the most desirable as it provides the best insulation value without disturbing existing building floors.
- 2. Without floor panels.** Vertical panels are constructed with flat bottoms which allow the panels to set directly on the concrete building floor. This arrangement can be used on all installations where height adjustment is not necessary.

Vertical panel height is the same for 4", 5" or 6" panels; however, overall Walk-In height is increased if floor or ceiling panels are used.

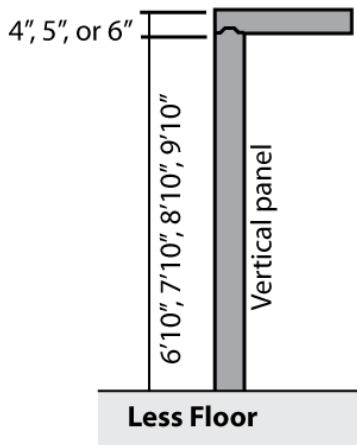
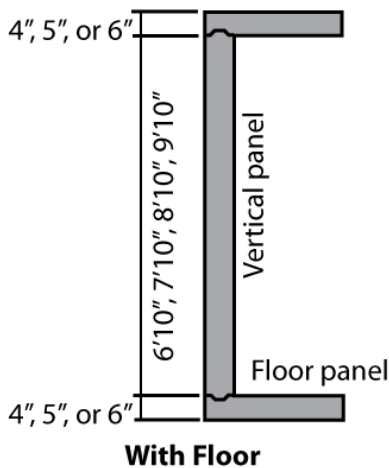

CLEARANCE REQUIREMENTS

A minimum space of 1" is required (*2" is recommended*) between Bally walls and the walls of existing buildings. The minimum distance between ceiling panels and an existing building ceiling is calculated as the ceiling panel thickness plus 2". This allowance provides space for air circulation to prevent moisture accumulation and accounts for deviations in building construction. Forced ventilation may be required in dead spaces without natural air movement.

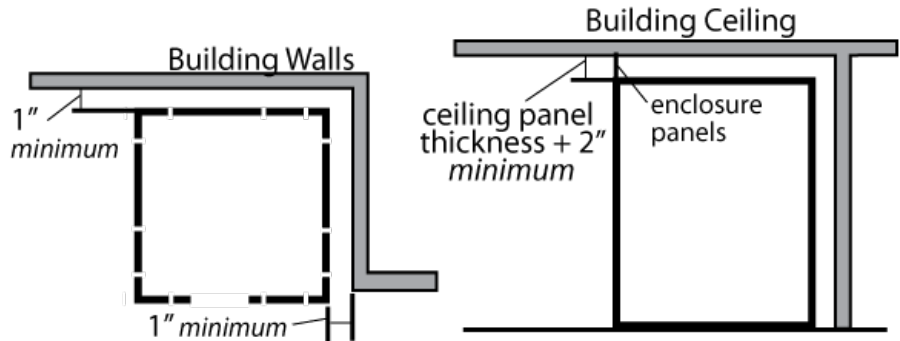

When self-contained refrigeration units are mounted to the Walk-In a minimum clearance is needed for proper air circulation and ease of maintenance. Top mounted units require a minimum 2' clearance between the top of the condensing unit and the building ceiling. Side mounted units require a minimum 2' clearance from the side of the condensing unit to the building wall.

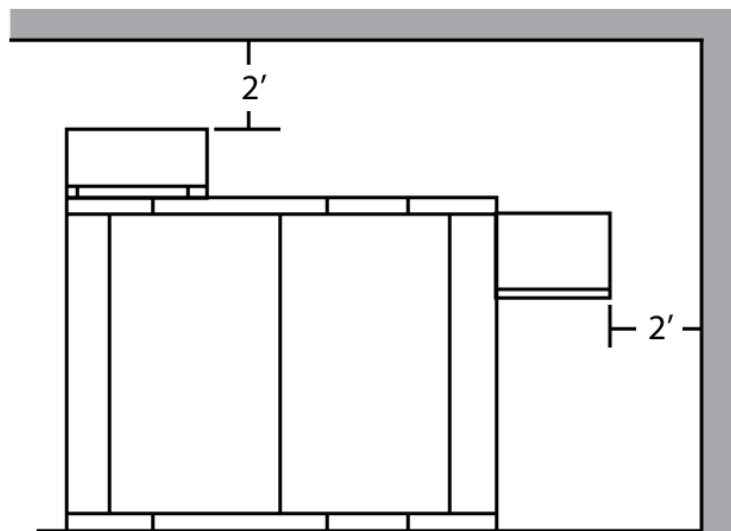

LOADING LIMITS

For proper refrigeration efficiency it is always necessary to provide adequate space above the stored product to allow for air circulation.

Height of Walk-in or Refrigerated Building	Space Between Ceiling and Top of Product
7'6"	12"
8'6"	19"
9'6", 10'6", 12'6"	24"
14' & above	30"

LAYOUT SUGGESTIONS

Standard Dimensions

Nominal	Actual	
	Outside Dimension	Inside Dimension
4'	3' 11"	3' 3"
5'	4' 10½"	4' 2½"
5½'	5' 4¼"	4' 8¼"
6'	5' 10"	5' 2"
6½'	6' 3¾"	5' 7¾"
7'	6' 9½"	6' 1½"
7½'	7' 3¼"	6' 7¼"
8'	7' 9"	7' 1"
8½'	8' 2¾"	7' 6¾"
9'	8' 8½"	8' ½"
9½'	9' 2¼"	8' 6¼"
10'	9' 8"	9'
10½'	10' 1¾"	9' 5¾"
11'	10' 7½"	9' 11½"
11½'	11' 1¼"	10' 5¼"
12'	11' 7"	10' 11"
12½'	12' ¾"	11' 4¾"
13'	12' 6½"	11' 10½"
13½'	13' ¼"	12' 4¼"
14'	13' 6"	12' 10"
14½'	13' 11¾"	13' 3¾"
15'	14' 5½"	13' 9½"
15½'	14' 11¼"	14' 3¼"
16'	15' 5"	14' 9"
16½'	15' 10¾"	15' 2¾"
17'	16' 4½"	15' 8½"
17½'	16' 10¼"	16' 2¼"
18'	17' 4"	16' 8"
18½'	17' 9¾"	17' 1¾"
19'	18' 3½"	17' 7½"
19½'	18' 9¼"	18' 1¼"
20'	19' 3"	18' 7"
20½'	19' 8¾"	19' ¾"

Nominal	Actual	
	Outside Dimension	Inside Dimension
21'	20' 2½"	19' 6½"
21½'	20' 8¼"	20' ¼"
22'	21' 2"	20' 6"
22½'	21' 7¾"	20' 11¾"
23'	22' 1½"	21' 5½"
23½'	22' 7¼"	21' 11¼"
24'	23' 1"	22' 5"
24½'	23' 6¾"	22' 10¾"
25'	24' ½"	23' 4½"
25½'	24' 6¼"	23' 10¼"
26'	25'	24' 4"
26½'	25' 5¾"	24' 9¾"
27'	25' 11½"	25' 3½"
27½'	26' 5¼"	25' 9¼"
28'	26' 11"	26' 3"
28½'	27' 4¾"	26' 8¾"
29'	27' 10½"	27' 2½"
29½'	28' 4¼"	27' 8¼"
30'	28' 10"	28' 2"
30½'	29' 3¾"	28' 7¾"
31'	29' 9½"	29' 1½"
31½'	30' 3¼"	29' 7¼"
32'	30' 9"	30' 1"
32½'	31' 2¾"	30' 6¾"
33'	31' 8½"	31' ½"
33½'	32' 2¼"	31' 6¼"
34'	32' 8"	32'
34½'	33' 1¾"	32' 5¾"
35'	33' 7½"	32' 11½"
35½'	34' 1¼"	33' 5¼"
36'	34' 7"	33' 11"
36½'	35' ¾"	34' 4¾"

Nominal	Actual	
	Outside Dimension	Inside Dimension
37'	35' 6½"	34' 10½"
37½'	36' ¼"	35' 4¼"
38'	36' 6"	35' 10"
38½'	36' 11¾"	36' 3¾"
39'	37' 5½"	36' 9½"
39½'	37' 11¼"	37' 3¼"
40'	38' 5"	37' 9"
40½'	38' 10¾"	38' 2¾"
41'	39' 4½"	38' 8½"
41½'	39' 10¼"	39' 2¼"
42'	40' 4"	39' 8"
42½'	40' 9¾"	40' 1¾"
43'	41' 3½"	40' 7½"
43½'	41' 9¼"	41' 1¼"
44'	42' 3"	41' 7"
44½'	42' 8¾"	42' ¾"
45'	43' 2½"	42' 6½"
45½'	43' 8¼"	43' ¼"
46'	44' 2"	43' 6"
46½'	44' 7¾"	43' 11¾"
47'	45' 1½"	44' 5½"
47½'	45' 7¼"	44' 11¼"
48'	46' 1"	45' 5"
48½'	46' 6¾"	45' 10¾"
49'	47' ½"	46' 4½"
49½'	47' 6¼"	46' 10¼"
50'	48'	47' 4"
50½'	48' 5¾"	47' 9¾"
51'	48' 11½"	48' 3½"
51½'	49' 5¼"	48' 9¼"
52'	49' 11"	49' 3"
52½'	50' 4¾"	49' 8¾"

8

SPECIFICATIONS

Trade Approvals

- **Underwriters Laboratories (UL):** Bally Refrigerated Boxes, Inc. 4", 5", and 6" panels generated a flame spread of 25 or lower and smoke generation of 450 or lower when tested in accordance with ASTM E-84.
- **Factory Mutual (FM):** Bally Refrigerated Boxes, Inc. 4", 5", and 6" panels meet that approval of FM standards as a Class 1 building type. FM approval depends on skin type and height of panel. Consult factory for specific qualifications for FM approval.
- **National Sanitation Foundation (NSF):** Bally Refrigerated Boxes, Inc. panels are NSF certified.
- **Energy Independence and Security Act of 2007 (EISA):** Bally Refrigerated Boxes, Inc. products manufactured after January 1, 2009, meet or exceed the act standards.
- **Miami Dade NOA# 12-0313.02**
- **City of Houston Approval #297**

Insulation

- Bally Refrigerated Boxes, Inc. uses HFC expanding agents to create a greater than 90% closed cell structure.
- Non-ozone depleting urethane shall be foamed-in-place (*poured, not frothed*) and, when completely heat cured, shall bind tenaciously to the metal skins to form an insulated panel. Panels and doors must meet or exceed minimum R-Values for cooler (*R-25*) and Freezer (*R-32*) when tested per ASTM C518 per Federal Regulation 431.304.

Panels

- Panels shall consist of interior and exterior metals skins precisely formed with steel and dies and roll-form equipment and thoroughly checked with gauges for accuracy. The metal skins shall be placed into heated molds and liquid urethane injected between them. For extra rigidity, the exteriors of all vertical panels above 118" except corners and door panels shall have vertical grooves spaced on 5-3/4" centers.
- Standard Panels shall contain 100% urethane insulation and have no internal wood or structural members to form tongue & groove profiles. Metal Skins shall have double 90° return bends for superior adhesion to urethane.
- To insure tight joints, panel edges must have foamed-in-place tongues and grooves with a flexible vinyl gasket on the interior and exterior of all tongue edges. Gaskets shall be NSF certified and resistant to damage from oil, fats, water and detergents.
- To assure perfect alignment and maximum strength, corner panels shall employ a right-angle configuration with exterior horizontal dimensions of 12" on each side.
- Vertical panels (**except corner panels**) shall be supplied in a single length up to 27'8" high (*16' high for installations with aluminum or stainless steel finish*).
- For outdoor applications, single-height panels greater than 19' (16' for aluminum) or multi-tiered vertical panels must be secured to horizontal girts mounted between building columns.
- Panels are available in 4", 5", or 6" thicknesses.

Joining Panels

- Panels shall be equipped with Bally Speed-Lok diaphragmatic joining devices.
- Each Speed-Lok shall consist of a cam action, hooked locking arm placed in one panel, and a steel rod positioned in the adjoining panel, so that when the arm is rotated, the hook engages the rod and draws the panels tightly together with cam action. Arms and rods shall be housed in individual steel pockets. Pockets on one side of the panel shall be connected to pockets on the other side in width, by the use of 2" wide metal straps set into and completely surrounded by the insulation.
- The distance between Speed-Loks shall not exceed 46".
- When panels are joined together, these straps shall form lock-to-lock connections for extra strength.

Finishes

Exterior Finishes

- Stucco-embossed Galvalume steel
- Stucco-embossed Aluminum
- Stucco-embossed White galvanized steel
- Stucco-embossed Stainless steel
- Stucco-embossed Sand-tan galvanized steel
- Stucco-embossed White Aluminum
- Smooth White galvanized steel
- Smooth Stainless steel (*20 ga or 22 ga*)
- Smooth White aluminum
- Galvanized steel (*Exterior ceilings in high wind areas*)

SPECIFICATIONS

Interior Finishes

- Stucco-embossed Galvalume steel
- Smooth White Galvanized steel
- Smooth Stainless steel (20 ga or 22 ga)
- Stucco-embossed Stainless steel
- Stucco-embossed Aluminum
- Stucco-embossed White aluminum
- Stucco-embossed White Galvanized steel
- Smooth White Aluminum
- Galvanized steel (for floors covered with quarry tile)
Custom finishes are available upon request.

Dimensions for Walk-In Refrigerators and/or Freezers

- **Lengths:** 5'10", 6'3³/₄", 6'9¹/₂", 7'3¹/₄", 7'9", 8'2³/₄", 8'8¹/₂", 9'2¹/₄", 9'8", 10'1³/₄", 10'7¹/₂", 11'1¹/₄", 11'7", 12'3³/₄", 12'6¹/₂", 13'6", 13'11³/₄", 14'5¹/₂", 14'11¹/₄", 15'5", 15'10³/₄", 16'4¹/₂", 16'10¹/₄", 17'4", 17'9³/₄", 18'3¹/₂", 18'9¹/₄", 19'3", 19'8³/₄", 20'2¹/₂", 20'8¹/₄", 21'2", 21'7³/₄", 22'7¹/₂", 22'7¹/₄", 23'1", 23'6³/₄", 24'1¹/₂", 24'6¹/₄", 25'0", 25'5³/₄", 25'11¹/₂", 26'5¹/₄", 26'11", 27'4³/₄", 27'10¹/₂". Longer buildings are available in additional 11¹/₂" increments.
- **Widths:** 5'10", 6'3³/₄", 6'9¹/₂", 7'3¹/₄", 7'9", 8'2³/₄", 8'8¹/₂", 9'2¹/₄", 9'8", 10'1³/₄", 10'7¹/₂", 11'1¹/₄", 11'7", 12'3³/₄", 12'6¹/₂", 13'6", 13'11³/₄", 14'5¹/₂", 14'11¹/₄", 15'5", 15'10³/₄", 16'4¹/₂", 16'10¹/₄", 17'4", 17'9³/₄", 18'3¹/₂", 18'9¹/₄", 19'3", 19'8³/₄", 20'2¹/₂", 20'8¹/₄", 21'2", 21'7³/₄", 22'7¹/₂", 22'7¹/₄", 23'1", 23'6³/₄", 24'1¹/₂", 24'6¹/₄", 25'0", 25'5³/₄", 25'11¹/₂", 26'5¹/₄", 26'11", 27'4³/₄", 27'10¹/₂". Wider buildings are available in additional 11¹/₂" increments.
- **Heights:** (heights shown are with floor; subtract 4" for less-floor units): 7'6", 8'6", 9'6", 10'6", 12', 13', 14', 15', 16', 17', 18', 19', 20'4", 21'4", 22'4", 23'4", 24'4", 25'4", 26'4", 27'4", 28'4". (*Single length verticals*) Taller buildings are available in additional 12" increments, with stacked vertical panels.

Floors

- Bally furnishes floor panels only. Preparation and Installation of Bally floor panels must be provided by others.
- Floor panel construction shall be similar to that of vertical panels, but with a heavier-gauge interior skin; thickness of floor panels may be different than that of vertical panels. The end floor panels (23.5" wide) will have extra cam locks (*than verticals*) to accommodate various panel configurations.
- Vertical panels shall lock to the floor panels using the Speed-Lok joining system.
- 4" thick floor panels have a 3/8" inside coved radius built in around the perimeter of skins and are NSF Certified. Coved trim is available for 5" and 6" floors also allowing them to be NSF Compliant.

Floor Types

- **Normal-usage Floor:** Floor panels shall be placed on a concrete pad and leveled. Where inside floor and outside platform must be level, the concrete pad shall be made with a depression deep enough to receive the Bally floor panels.
- **Reinforced Floor:** 1/2" Plywood or 1/2" OSB with .100 Smooth Aluminum and/or 16 Ga. Stainless-Steel plus overlay of 3/16" Aluminum Diamond Tread. These panels are designed to support a "uniformly distributed load" of 2,500 lbs. per square foot.
- **Heavy Reinforced Floor:** 3" Steel C-stud combined with 1/2" Plywood or 1/2" OSB with 16 Ga. Stainless Steel or .100 Smooth Aluminum foamed in place (4" or 3-5/8" NSF panels) plus an overlay of 3/16" Aluminum Diamond Tread. Heavy traffic cooler (to limit thermal transmission) low volume keg coolers and other heavy use applications. These panels are designed to support a "uniformly distributed load" of 3,000 lbs. per square foot.
- **Built-in, Insulated Floor:** The floor shall be constructed on the job site. It shall consist of a depressed, reinforced concrete sub-slab. Slab urethane (*thickness based on temperature requirements*) or insulated Bally panels shall be built into this depressed slab, add a minimum of 4" reinforced concrete wearing floor to be installed on top. Wall panels shall be fastened to this floor, or locked to Bally floor panels prior to installation of concrete wearing surface. Adequate drainage and ventilation or other heat source must be provided beneath and around all construction. Forklift use is permitted when tile surface is NOT used.
- **Structured Floor Panels:** 4", 5" or 6" thick insulated floor panels contain non-conductive fiberglass structural imbeds, with an additional 3/4" Plywood adhered to the floor skin, for maximum strength without freezing. 1/4" or 3/16" Diamond Tread plate overlay adds additional strength. Panels are designed to support a "rolling load" of 4,000 lbs. per square foot. Examples; pallet jacks, large equipment, heavy carts with small wheels and high volume large keg coolers. Forklift use is NOT permitted.

Floor Panel Finishes

- 16 ga. Stainless steel
- .080 Rigidized Aluminum
- .100 Smooth Aluminum
- 16 ga. Galvanized Steel
- .125 Aluminum Diamond Tread
- .060 Rigidized Stainless Steel

SPECIFICATIONS

Doors

- Number of doors, location and direction of swing shall be specified in the Walk-In layout.
- Doors are in-fitting and flush-mounted, and conform to the same standards as vertical panels.
- Magnetic core, thermoplastic gaskets installed on the top edge and both sides of the door shall keep the door in a closed position, forming a tight seal; a flexible, dual blade wiper gasket shall be installed at the bottom of the door.
- NSF Certified gaskets shall be replaceable and resistant to damage from oil, fats, water and detergent.
- A heavy U-channel structural steel frame around the perimeter of the door opening shall prevent racking or twisting; steel frame is to be reinforced for hardware attachment.
- Anti-condensate heater wire shall be concealed behind the metal edge of the doorjamb.

The door panel shall also include:

- Vapor-proof LED interior lamp; junction box for 120/60/1 AC service (15 amp maximum);
- 2"-dia. flush-face dial thermometer (*field mounted on 60" wide doors*); Provides dual temperature readings in a range from -60°F to 80°F.
- Door Canopy – rain shield for outdoor installations, to be caulked and mechanically attached to door.

Door Hardware

- For doors with 30", 34", 36", or 42" wide openings: two spring-loaded, cam-lift, self-closing hinges; cylinder latch with provision for padlocking and safety release mechanism; door closer.
- For doors with 48" or 60" wide openings: hinges are uplift type with blades not less than 9" long; latch shall include provision for padlocking and safety release mechanism. Bally recommends 4 hinges for all 60" wide doors.

Hardware Finishes

- For Walk-Ins finished with stainless steel – polished aluminum
- For Walk-Ins with finishes other than stainless steel – satin aluminum

Door Dimensions:

- Standard Widths: 30", 34", 36", 42", 48", 60"
- Standard Heights: 66", 70", 78", 84" - Doors can be cut to accommodate thickness of tile, if applicable.

Door Options

- Hinged Super Entrance Door:
Construction is identical to that of a standard door except that a third hinge is added and the door and portion of door panel is protected by diamond-plate kick panels covering the bottom 30" on interior and exterior.

Hinged Super Entrance Door Dimensions:

- Widths: 30", 34", 36", 42", 48", 60"
- Heights: 66", 70", 78", 84"
- **Observation Window in Entrance Door:** a 14" x 14" heated observation window shall be provided in the entrance door. It consists of three panes of glass with either heat reflective treated glass or Argon gas filled. 14"x24" windows shall be used on larger doors (48" to 60" wide). Window heat system shall be controlled by a thermostat to minimize energy consumption.
- Deadbolt Handle Latch: Security latch with sliding deadbolt and inside safety release.
- Strip Curtain: Sturdy, NSF Certified, clear-vinyl strip curtains shall permit easy passage while minimizing air infiltration. Made of USDA-approved, polyester reinforced, clear vinyl strips, eight inches wide with rounded edges.

Accessories

- Pressure Relief Port (*required for all freezers*)
- Partition Walls: Insulated, 4" thick metal clad panels shall be provided to form separate compartments within the Walk-In. A non-conductor strip must be built into all exterior panels at the joints where partitions butt to prevent transfer of heat from one compartment to another. Partition panels shall be locked to these panels.
- **Roof Options:** (*One of the following types must be used for any outdoor installation*):
 - Sectional prefab metal roof shall be used with structures installed outdoors on buildings of any length but not exceeding 34'7" in width. Roofs shall be made of stucco-embossed aluminum.
 - Single-piece, pre-sized membrane roof system; maximum dimensions: 34'7" x 34'7".

- Bally reviews factors including existing building locations, snow loads, and wind factors to determine the correct roof/ceiling design for the specific installation.
- **Alarm Systems:** Modularm 75L C • National TM166 • Weiss XWA
- **Double-swing Cart Door:** used in tandem with Bally hinged entrance doors to minimize the entry of heat when main doors must be kept open. May be installed on units operating at temperatures as low as -20°F. Available with optional bumpers.
- **Reach-in Doors:** Convenient for Product loading these doors can be designed where any regular 46" panel is used. Construction and hardware standards are equal to that of typical door panels.
Sizes: 18½" x 30" or 30" x 30": Single _____ Size _____: Double _____ Size _____
- **Glass Display Doors:** Provide maximum display. Available for cooler or freezer applications, low temperature doors have built-in heaters to eliminate condensation; can be installed with left-hand or right-hand swings and optional locks. Shelving also available. Number _____ Size _____
- **Wire Shelving**
 - **Cantilevered:** Stainless steel top anchors held in place by zinc-plated steel sheet metal screws. Two stainless steel support brackets support shelves positioned over nylon projections and finished with closure caps. All shelves have raised wire edges to keep stored product in place.
Finishes: chrome, epoxy, or stainless steel.
Number of Tiers: _____ **Widths:** 14", 21" **Lengths:** 30", 36", 42", 48", 54", 60" (other lengths available upon request)
 - **Freestanding:** Allow for free air circulation, and easy assembly. Bolt levelers on the feet ensure level shelving.
Finishes: chrome, epoxy, stainless steel, and flat and louvered stainless steel
Number of Tiers: _____ **Widths:** 14", 21" **Lengths:** 36", 48", 60"
- **Lighting:** 24" long LED • 48" long fluorescent • 48" long LED • High Bay LED Lights • High Bay LED Lights

Refrigeration Systems (For multi-compartment units, provide plan view with compartment temperatures.)

- **Condensing Units:** Indoors or Outdoors • Horsepower or BTU rating at a specified condition • Voltage & Phase
Compressor Types: Scroll • Hermetic • Semi-hermetic
 - Various controls and option packages available
- **Evaporators:** Preassembled remote • EC motor standard • SmartSpeed™ fan control standard

Installation

- Installation Manuals shall be provided upon delivery of the Walk-In.
- Installation Manual will include instructions for the erection of the Walk-In, and any subsequent materials will be provided for optional Accessories, and Refrigeration Systems.

Work & Materials

- Materials shall be in full accordance with local and/or state ordinances, and with any other prevailing rules and regulations.
- Bally Refrigerated Boxes, Inc. is not responsible for furnishing items required by the regulations, unless specified or shown on the drawings or contained in the specifications.

Warranties

- Bally shall warrant that any part of the structure it supplies (except the refrigeration system and its related accessories) is free from defects in materials or workmanship under normal use and service.
- The insulated panel portion of the structure is warranted free from defects under normal use and service for a period of 10 years from date of installation (but in no event shall the warranty be in force for more than 10 years and 6 months from the date the product was first shipped by Bally).
- Panel surface condition is warranted free from defects under normal use and service for one year from installation, provided the panel is stored and installed according to Bally's instructions.
- Mechanical (including hardware, gasketing, Speed-Lok assemblies, weather roofs) and electrical components, except refrigeration systems (which are covered by a separate warranty) are warranted to be free from defects under normal use and service for one year from date of installation. (In no case shall this portion of the warranty be in force for more than one year and six months from the date the product was first shipped by Bally.)
- The warranty shall not include any labor charges for replacement or repair of defective parts or refrigeration. Full warranty information is to be provided with the Walk-In.

9

REFRIGERATION EQUIPMENT

Bally provides a full line of ozone-friendly Refrigeration Equipment specially configured for each Bally installation.

Bally Pre-Assembled Remote Refrigeration Systems:

Designed for installations where condensing units are mounted away from the Walk-In. These systems include an evaporator and condensing unit.

Bally Pre-Charged Refrigeration Systems:

Require minimal jobsite connections. They include an evaporator and pre-charged condensing unit.

Refrigeration options include:

- Global voltages in 50 Hz and 60 Hz applications
- Hermetic units
- Semi-hermetic units
- Scroll
- Pre-charged systems with pre-charged line sets
- Refrigerant shipped with condensing units
- Oil shipped with condensing units

Bally Evaporators:

Evaporators are available for a variety of applications from low-velocity to large blast freezers. All evaporators are available with optional materials and coatings in addition to factory installed controls and valves such as room- and liquid-line thermostats.

Plug Systems:

Plug refrigeration systems are fully piped and wired and ready to drop into a ceiling panel's factory-cut opening. No refrigeration technicians are required to install the refrigeration unit. Systems are available in Medium Temperature: ½ to 1½ HP, and Low Temperature 1 - 2½ HP.

SmartSpeed®:

Systems connected to SmartSpeed® technology will benefit with extra energy savings up to 10% on compressor consumption, and 40% on evaporator consumption.

SmartVap™ II:

Bally's SmartVap™ II is a simple control located in the evaporator that controls box temperature, defrost initiation, defrost termination, and fan delay. It is factory pre-set to suit most applications, field adjustable for unique applications, and has an extremely simple user interface. Available for electric defrost single phase evaporators, up to 25 Amp. maximum overcurrent protection. Consult factory for other applications.

Thermosaver Hot Gas Defrost System:

The fast, efficient, positive defrosting of evaporators is three times faster than electric defrost systems, and creates energy savings through a reduction in box temperature rise, minimal product deterioration and reduced power consumption. Shorter defrost cycle periods provide increased refrigeration time allowing smaller equipment sizing and lower initial equipment costs. We pre-pipe all valves, and install defrost-termination and fan-delay pressure controls at the factory. The Thermosaver™ is available on all Air, Remote and Water Cooled Bally Condensing Units and single or multiple Evaporator Systems.

REFRIGERATION EQUIPMENT

EVAPORATORS

Model	Type	Defrost	BTUH at 10°F TD
BLP-LINE	Low Profile	Air, Electric, and Hot Gas	4,100 to 30,600
BMP-LINE	Medium Profile	Air, Electric, and Hot Gas	18,000 to 88,000
BTL-LINE	Two Way Low Profile	Air and Electric	870 to 11,500
BTM-LINE	Two Way Medium Profile	Air and Electric	870 to 11,500
BLV-LINE	Low Velocity	Air, Electric, and Hot Gas	6,000 to 37,000
BHP-LINE	High Profile	Air	55,000 to 278,000
BHP-LINE	High Profile	Electric	55,000 to 278,000
BHP-LINE	High Profile	Hot Gas	55,000 to 278,000

CONDENSING UNITS

Model	Location	Cooling Type	Compressor Type	Temperature Applications	HP
BEH-LINE	Indoor/Outdoor	Air	Hermetic	High, Medium, & Low	½ to 7.5
BEZ-LINE	Indoor/Outdoor	Air	Scroll	High, Medium, & Low	1 to 10
BQ-LINE	Outdoor	"Quiet" Air	Hermetic & Scroll	High, Medium, Extended Medium, & Low	1 to 6
BES-LINE	Indoor/Outdoor	Air	Semi-Hermetic	High, Medium, & Low	½ to 22
BMH-LINE	Indoor/Outdoor	Compact Air	Hermetic	High, Medium, Extended Medium, & Low	½ to 5
BX-LINE	Indoor	Water	Coaxial	High, Medium, & Low	½ to 5
BW-LINE	Indoor	Water	Semi-Hermetic	High, Medium, & Low	½ to 40
BF-LINE	Indoor/Outdoor	Air	Multi-compressor	High, Medium, & Low	½ to 6 per fan 18 per unit
BV-LINE	Outdoor	Air	Semi-Hermetic	High/Medium	15 to 100
				Low	10 to 80
BM-LINE	Outdoor	Air	Semi-Hermetic	High/Medium	6 to 40
				Low	7½ to 44
RB-LINE	Indoor Remote	Air	Semi-Hermetic	High, Medium, & Low	½ to 40

CONDENSERS

Model	Cooling Type	Air Discharge	Nominal Tons	
BCS-LINE	Air	Vertical or Horizontal	2 to 24	refrigeration or air conditioning duty
BCM-LINE	Air	Vertical or Horizontal	9 to 48	refrigeration or air conditioning duty
BCL-LINE	Air	Vertical or Horizontal	7 to 270	1 to 14 fan (double width) models THR (R404A, 25°F TD, 60 Hz)

EVAPORATORS

BTM-Line, Center-Mount Two Way Evaporators

Reach-in and walk-in cooler flexibility is provided with this flush ceiling mounted evaporator. Designed with dual refrigeration coils and two-way air distribution, effectively reducing air velocities and minimizing product dehydration.

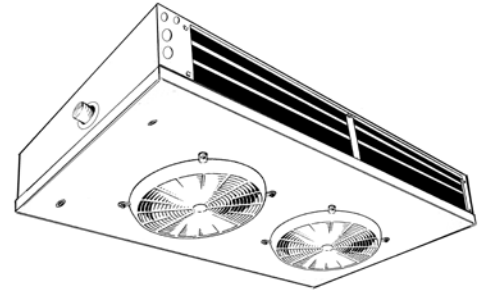

115/1/60, 208-230/1/60, 208-230/3/60

DIMENSIONS In. (mm)

MODEL	BTM	HEIGHT	WIDTH	DEPTH
115M	105L	8 11/16 (221)	67 1/2 (1715)	26 1/2 (673)
139M	124L	8 11/16 (221)	67 1/2 (1715)	26 1/2 (673)
172M	153L	8 11/16 (221)	93 1/2 (2375)	26 1/2 (673)
208M	188L	8 11/16 (221)	93 1/2 (2375)	26 1/2 (673)
236M	210L	8 11/16 (221)	93 1/2 (2375)	26 1/2 (673)
260M	235L	8 11/16 (221)	113 1/2 (2883)	26 1/2 (673)
295M	265L	8 11/16 (221)	113 1/2 (2883)	26 1/2 (673)

AIR DEFROST - MEDIUM TEMPERATURE

MODEL BTM	BTUH +25°F ET @ 10°F TD	CFM	QTY.	MOTOR DATA				CONNECTIONS		Approx. Ship Weight - lbs. (kg)
				115/1/60		208-230/1/60		LIQUID (OD)	SUCTION (OD)	
				FLA	MCA	FLA	MCA			
115MA	11500	2020	2	2.4	2.7	1.4	1.6	1/2	7/8	110 (50)
139MA	13900	1900	2	2.4	2.7	1.4	1.6	1/2	7/8	116 (53)
172MA	17200	3030	3	3.6	3.9	2.1	2.3	1/2	7/8	150 (68)
208MA	20800	2850	3	3.6	3.9	2.1	2.3	1/2	1 1/8	157 (71)
236MA	23600	3700	4	4.8	5.1	2.8	3.0	1/2	1 1/8	164 (74)
260MA	26000	3780	4	4.8	5.1	2.8	3.0	7/8	1 1/8	191 (87)
295MA	29500	4630	5	6.0	6.3	3.5	3.7	7/8	1 1/8	198 (90)



ELECTRIC DEFROST - MEDIUM TEMPERATURE

MODEL BTM	BTUH +20°F ET @ 10°F TD	CFM	QTY.	MOTOR DATA				HEATER DATA			CONNECTIONS		Approx. Ship Weight - lbs. (kg)
				208-230/1/60		208-230/3/60		TOTAL WATTS	208-230/1/60		LIQUID (OD)	SUCTION (OD)	
				FLA	MCA	FLA	MCA		FLA	MCA			
115MA	11500	2020	2	1.4	1.6	1.4	1.6	2600	11.3	14.1	1/2	7/8	110 (50)
139MA	13900	1900	2	1.4	1.6	1.4	1.6	2600	11.3	14.1	1/2	7/8	116 (53)
172MA	17200	3030	3	2.1	2.3	2.1	2.3	3720	16.2	20.3	1/2	7/8	150 (68)
208MA	20800	2850	3	2.1	2.3	2.1	2.3	3720	16.2	20.3	1/2	1 1/8	157 (71)
236MA	23600	3700	4	2.8	3.0	2.8	3.0	3720	16.2	20.3	1/2	1 1/8	164 (74)
260MA	26000	3780	4	2.8	3.0	2.8	3.0	4560	19.8	24.8	7/8	1 1/8	191 (87)
295MA	29500	4630	5	3.5	3.7	3.5	3.7	4560	19.8	24.8	7/8	1 1/8	198 (90)

ELECTRIC DEFROST - LOW TEMPERATURE

MODEL BTM	BTUH -20°F ET @ 10°F TD	CFM	QTY.	MOTOR DATA				HEATER DATA			CONNECTIONS		Approx. Ship Weight - lbs. (kg)
				208-230/1/60		208-230/3/60		TOTAL WATTS	208-230/1/60		LIQUID (OD)	SUCTION (OD)	
				FLA	MCA	FLA	MCA		FLA	MCA			
105LE	10500	2020	2	1.4	1.6	1.4	1.6	2600	11.3	14.1	1/2	7/8	110 (50)
124LE	12400	1900	2	1.4	1.6	1.4	1.6	2600	11.3	14.1	1/2	1 1/8	116 (53)
153LE	15300	3030	3	2.1	2.3	2.1	2.3	3720	16.2	20.3	1/2	1 1/8	150 (68)
188LE	18800	2850	3	2.1	2.3	2.1	2.3	3720	16.2	20.3	7/8	1 1/8	157 (71)
210LE	21000	3700	4	2.8	3.0	2.8	3.0	3720	16.2	20.3	7/8	1 1/8	164 (74)
235LE	23500	3780	4	2.8	3.0	2.8	3.0	4560	19.8	24.8	7/8	1 3/8	191 (87)
265LE	26500	4630	5	3.5	3.7	3.5	3.7	4560	19.8	24.8	7/8	1 3/8	198 (90)

EVAPORATORS

BLP-Line, Low Profile Evaporators

The BLP low profile evaporator is designed for -30°F and above room temperatures. Designed for maximum performance and dependability, storage space is optimized by the compact, slim profile which provides uniform air distribution through the coil for optimal heat transfer performance. Available in twelve sizes ranging in capacity from 3,800 to 39,000 BTUH.

Our most popular unit cooler, the BLP features a flush to ceiling textured aluminum cabinet, stainless steel and nylon hardware, high efficiency fan motors, high density polyethylene fan guards with built in throw boosters, and reversible, formed drain pan with field installed nylon drain pan fitting. Electric defrost models include corrosion resistant stainless steel heater elements face mounted on the entering air side of the coil allowing for easy service and accessibility; stainless steel heater element supplied below the coil for improved condensate removal; and a factory mounted combination fan delay/defrost termination thermostat control (fixed setting). Units can be field modified for 3 Phase heater wiring.



115/1/60, 208-230/1/60, 208-230/3/60, 460/1/60, 200-220/1/50, 200-220/3/50 and 380-400/1/50

SmartSpeed
TECHNOLOGY

Upgrade the package with factory installed expansion valve, solenoid valve and room thermostat.

AIR DEFROST - MEDIUM TEMPERATURE - 6 FPI

MODEL BLP	BTUH +25°F ET @ 10°F TD	CFM	MOTOR DATA - 1/15 HP each						DIMENSIONS In. (mm)						CONNECTIONS		Approx. Ship Weight - lbs. (kg)
			QTY.	115/1/60		208-230/1/60		HEIGHT	WIDTH	DEPTH	LIQUID (OD)	SUCTION (OD)					
				FLA	MCA	FLA	MCA										
104MA	4300	1010	1	1.0	1.3	0.6	0.8	15 7/8 (403)	30 1/4 (768)	15 (381)	5/8	1/2	45 (20)				
106MA	5500	950	1	1.0	1.3	0.6	0.8	15 7/8 (403)	30 1/4 (768)	15 (381)	5/8	1/2	47 (21)				
107MA	6800	900	1	1.0	1.3	0.6	0.8	15 7/8 (403)	30 1/4 (768)	15 (381)	5/8	1/2	49 (22)				
209MA	8600	2020	2	2.0	2.3	1.2	1.4	15 7/8 (403)	46 1/4 (1175)	15 (381)	7/8	1/2	70 (32)				
211MA	11000	1910	2	2.0	2.3	1.2	1.4	15 7/8 (403)	46 1/4 (1175)	15 (381)	7/8	1/2	74 (33)				
214MA	14000	1800	2	2.0	2.3	1.2	1.4	15 7/8 (403)	46 1/4 (1175)	15 (381)	7/8	1/2	78 (35)				
317MA	17000	2860	3	3.0	3.3	1.8	2.0	15 7/8 (403)	62 1/4 (1581)	15 (381)	7/8	1/2	101 (46)				
320MA	20000	2700	3	3.0	3.3	1.8	2.0	15 7/8 (403)	62 1/4 (1581)	15 (381)	7/8	1/2	107 (48)				
423MA	23000	3810	4	4.0	4.3	2.4	2.6	15 7/8 (403)	78 1/4 (1988)	15 (381)	1 1/8	1/2	117 (53)				
426MA	26000	3600	4	4.0	4.3	2.4	2.6	15 7/8 (403)	78 1/4 (1988)	15 (381)	1 1/8	1/2	135 (61)				
532MA	32000	4500	5	5.0	5.3	3.0	3.2	15 7/8 (403)	94 1/4 (2394)	15 (381)	1 3/8	1/2	163 (74)				
639MA	39000	5400	6	6.0	6.3	3.6	3.8	15 7/8 (403)	110 1/4 (2800)	15 (381)	1 3/8	7/8	192 (87)				

ELECTRIC DEFROST - MEDIUM TEMPERATURE - 6 FPI

MODEL BLP	BTUH +20°F ET @ 10°F TD	CFM	MOTOR DATA 1/15 HP each				HEATER DATA				DIMENSIONS In. (mm)						CONNECTIONS		Approx. Ship Weight - lbs. (kg)
			QTY.	208-230/1/60		TOTAL WATTS	208-230/1/60		208-230/3/60		HEIGHT	WIDTH	DEPTH	LIQUID (OD)	SUCTION (OD)				
				FLA	MCA		FLA	MCA	FLA	MCA									
104ME	4300	1010	1	0.6	0.8	1060	4.6	5.8	3.8	15	15 7/8 (403)	30 1/4 (768)	15 (381)	5/8	1/2	49 (22)			
106ME	5500	950	1	0.6	0.8	1060	4.6	5.8	3.8	15	15 7/8 (403)	30 1/4 (768)	15 (381)	5/8	1/2	51 (23)			
107ME	6800	900	1	0.6	0.8	1060	4.6	5.8	3.8	15	15 7/8 (403)	30 1/4 (768)	15 (381)	5/8	1/2	53 (24)			
209ME	8600	2020	2	1.2	1.4	1890	8.2	10.3	6.7	15	15 7/8 (403)	46 1/4 (1175)	15 (381)	7/8	1/2	76 (34)			
211ME	11000	1910	2	1.2	1.4	1890	8.2	10.3	6.7	15	15 7/8 (403)	46 1/4 (1175)	15 (381)	7/8	1/2	80 (36)			
214ME	14000	1800	2	1.2	1.4	1890	8.2	10.3	6.7	15	15 7/8 (403)	46 1/4 (1175)	15 (381)	7/8	1/2	84 (38)			
317ME	17000	2860	3	1.8	2.0	2730	11.9	14.8	10	15	15 7/8 (403)	62 1/4 (1581)	15 (381)	7/8	1/2	109 (49)			
320ME	20000	2700	3	1.8	2.0	2730	11.9	14.8	10	15	15 7/8 (403)	62 1/4 (1581)	15 (381)	7/8	1/2	115 (52)			
423ME	23000	3810	4	2.4	2.6	3560	15.5	19.3	12	15	15 7/8 (403)	78 1/4 (1988)	15 (381)	1 1/8	1/2	127 (58)			
426ME	26000	3600	4	2.4	2.6	3560	15.5	19.3	12	15	15 7/8 (403)	78 1/4 (1988)	15 (381)	1 1/8	1/2	145 (66)			
532ME	32000	4500	5	3.0	3.2	4400	19.1	23.9	15.1	20	15 7/8 (403)	94 1/4 (2394)	15 (381)	1 3/8	1/2	176 (80)			
639ME	39000	5400	6	3.6	3.8	5230	22.7	28.4	18	20	15 7/8 (403)	110 1/4 (2800)	15 (381)	1 3/8	7/8	207 (94)			

ELECTRIC DEFROST - LOW TEMPERATURE - 6 FPI

MODEL BLP	BTUH -20°F ET @ 10°F TD	CFM	MOTOR DATA 1/15 HP each				HEATER DATA				DIMENSIONS In. (mm)						CONNECTIONS		Approx. Ship Weight - lbs. (kg)
			QTY.	208-230/1/60		TOTAL WATTS	208-230/1/60		208-230/3/60		HEIGHT	WIDTH	DEPTH	LIQUID (OD)	SUCTION (OD)				
				FLA	MCA		FLA	MCA	FLA	MCA									
104LE	3800	1010	1	0.6	0.8	1060	4.6	5.8	3.8	15	15 7/8 (403)	30 1/4 (768)	15 (381)	5/8	1/2	49 (22)			
105LE	4800	950	1	0.6	0.8	1060	4.6	5.8	3.8	15	15 7/8 (403)	30 1/4 (768)	15 (381)	5/8	1/2	51 (23)			
106LE	5800	900	1	0.6	0.8	1060	4.6	5.8	3.8	15	15 7/8 (403)	30 1/4 (768)	15 (381)	5/8	1/2	53 (24)			
207LE	7400	2020	2	1.2	1.4	1890	8.2	10.3	6.7	15	15 7/8 (403)	46 1/4 (1175)	15 (381)	7/8	1/2	76 (34)			
209LE	9000	1910	2	1.2	1.4	1890	8.2	10.3	6.7	15	15 7/8 (403)	46 1/4 (1175)	15 (381)	7/8	1/2	80 (36)			
211LE	11000	1800	2	1.2	1.4	1890	8.2	10.3	6.7	15	15 7/8 (403)	46 1/4 (1175)	15 (381)	7/8	1/2	84 (38)			
314LE	14000	2860	3	1.8	2.0	2730	11.9	14.8	10	15	15 7/8 (403)	62 1/4 (1581)	15 (381)	7/8	1/2	109 (49)			
317LE	17000	2700	3	1.8	2.0	2730	11.9	14.8	10	15	15 7/8 (403)	62 1/4 (1581)	15 (381)	7/8	1/2	115 (52)			
419LE	19000	3810	4	2.4	2.6	3560	15.5	19.3	12	15	15 7/8 (403)	78 1/4 (1988)	15 (381)	1 1/8	1/2	127 (58)			
422LE	22000	3600	4	2.4	2.6	3560	15.5	19.3	12	15	15 7/8 (403)	78 1/4 (1988)	15 (381)	1 1/8	5/8	145 (66)			
527LE	27000	4500	5	3.0	3.2	4400	19.1	23.9	15.1	20	15 7/8 (403)	94 1/4 (2394)	15 (381)	1 3/8	5/8	176 (80)			
631LE	31000	5400	6	3.6	3.8	5230	22.7	28.4	18	20	15 7/8 (403)	110 1/4 (2800)	15 (381)	1 3/8	5/8	207 (94)			

CONDENSING UNITS

BES-Line, Outdoor Air Cooled Semi-Hermetic Condensing Units

Models range in capacity from 1/2 HP to 22 HP for high/medium, medium and low temperature applications. BES units are available with Copeland or Bitzer compressors along with many standard features, giving you the quality you expect and the options you demand. Its spacious serviceable design is sure to make BES units a favorite of installers.



R404A R507 R407C



In addition to the many options available, five factory-installed option packages have been pre-selected for your convenience.

208-230/1/60, 208/1/60, 208-230/3/60, 460/3/60, 575/3/60, 200-220/1/50, 200/1/50, 200-220/3/50 and 380-400/3/50

COPELAND - R404A R507 HIGH/MEDIUM TEMPERATURE

MODEL BESA	COMPR. MODEL	BTUH @ 95°F Amb.		MINIMUM CIRCUIT AMPACITY			DIMENSIONS In. (mm)			CONN.		Approx. Ship Weight - lbs. (kg)
		25°F SST	0°F SST	208-230/3/60	460/3/60	575/3/60	HEIGHT	WIDTH	DEPTH	LIQ.	SUCT.	
050H8	2DC3-0500E	45240	25770	30	14.1	10.5	41 7/8 (1064)	52 1/8 (1324)	43 (1092)	1/2	1 1/8	721 (327)
051H8	2DD3-0500E	52880	30720	30	14.2	10.8	41 7/8 (1064)	52 1/8 (1324)	43 (1092)	1/2	1 1/8	724 (328)
075H8	2DL3-0750E	62190	37370	41.6	18.4	17.4	41 7/8 (1064)	52 1/8 (1324)	50 (1270)	5/8	1 3/8	735 (333)
076H8	2DA3-0750E	69480	43340	42.1	18.7	17.5	41 7/8 (1064)	65 1/8 (1654)	50 (1270)	5/8	1 3/8	735 (333)
080H8	3DA3R10ME	85500	51900	55.5	27.2	22.4	41 7/8 (1064)	65 1/8 (1654)	50 (1270)	5/8	1 3/8	830 (376)
100H8	3DB3R12ME	98300	61300	58.7	27.2	22.4	41 7/8 (1064)	65 1/8 (1654)	50 (1270)	5/8	1 3/8	830 (376)
120H8	3DF3R15ME	125400	77200	67.3	32.9	-	45 1/2 (1156)	75 7/8 (1927)	59 (1156)	7/8	1 3/8	1030 (467)
150H8	3DS3R17ME	136100	84500	81.7	39.7	32.3	45 1/2 (1156)	75 7/8 (1927)	59 (1156)	7/8	1 3/8	1030 (467)
200H8	4DA3R18ME	141200	85300	80.6	40.2	32.6	45 1/2 (1156)	75 7/8 (1927)	59 (1156)	7/8	1 3/8	1030 (467)

COPELAND - R404A R507 MEDIUM TEMPERATURE

MODEL BESA	COMPR. MODEL	BTUH @ 95°F Amb.		MINIMUM CIRCUIT AMPACITY				DIMENSIONS In. (mm)			CONN.		Approx. Ship Weight - lbs. (kg)
		25°F SST	0°F SST	208-230/1/60	208-230/3/60	460/3/60	575/3/60	HEIGHT	WIDTH	DEPTH	LIQ.	SUCT.	
010M6	KARB-010E	9360	5600	9.8	5.9	-	-	16 7/8 (429)	24 7/8 (632)	34 3/8 (873)	3/8	5/8	270 (122)
020M6	KAKA-020E	15400	9050	14.4	9.6	-	-	19 7/8 (505)	36 3/8 (924)	34 3/8 (873)	3/8	7/8	320 (145)
021M6	ERCA-021E	19400	11300	-	12.1	5.5	4.5	19 7/8 (505)	36 3/8 (924)	34 3/8 (873)	3/8	7/8	390 (177)
030M6	ERFA-031E	28360	16640	23.4	17.6	8.4	-	30 3/8 (772)	47 3/8 (1203)	43 (1092)	1/2	4/8	477 (217)

COPELAND - R404A R507 LOW TEMPERATURE

MODEL BESA	COMPR. MODEL	BTUH @ 95°F Amb.		MINIMUM CIRCUIT AMPACITY				DIMENSIONS In. (mm)			CONN.		Approx. Ship Weight - lbs. (kg)
		-10°F SST	-20°F SST	208-230/1/60	208-230/3/60	460/3/60	575/3/60	HEIGHT	WIDTH	DEPTH	LIQ.	SUCT.	
005L6	KANB-005E	2750	1960	5.0	3.3	-	-	16 7/8 (429)	24 7/8 (632)	34 3/8 (873)	3/8	1/2	240 (109)
008L6	KAMB-007E	4580	3440	7.5	4.5	-	-	16 7/8 (429)	24 7/8 (632)	34 3/8 (873)	3/8	5/8	270 (122)
010L6	KAJB-010E	5760	4460	9.1	6.3	-	-	16 7/8 (429)	24 7/8 (632)	34 3/8 (873)	3/8	7/8	290 (132)
015L6	KALB-015E	8960	6910	13.5	9.4	4.9	-	19 7/8 (505)	36 3/8 (924)	34 3/8 (873)	3/8	7/8	315 (143)
020L6	EADB-021E	10100	7590	13.6	9.6	-	-	19 7/8 (505)	36 3/8 (924)	34 3/8 (873)	3/8	7/8	385 (175)
021L6	EAVB-021E	11400	8770	19.5	10.4	5.5	4.4	19 7/8 (505)	36 3/8 (924)	34 3/8 (873)	1/2	7/8	390 (177)
030L6	LAHA-032E	18630	13920	23.0	18.1	8.6	6.0	30 3/8 (772)	47 3/8 (1203)	43 (1092)	1/2	1 1/8	493 (224)
031L6	NRD1-032E	21060	16480	36.7	22.5	11.6	-	30 3/8 (772)	47 3/8 (1203)	43 (1092)	1/2	1 1/8	562 (255)
032L6	LACA-032E	-	18780	21.5	18.1	8.6	-	30 3/8 (772)	47 3/8 (1203)	43 (1092)	1/2	1 1/8	491 (223)
035L6	2DF3-030E	24080	18780	-	23.1	11.2	9.3	30 3/8 (772)	47 3/8 (1203)	43 (1092)	1/2	1 1/8	588 (267)
040L6	2DL3-040E	29510	23110	-	35.0	13.9	10.5	30 3/8 (772)	47 3/8 (1203)	43 (1092)	1/2	1 1/8	618 (281)
060L6	2DB3-060E	36760	28840	-	37.4	17.7	12.9	41 7/8 (1064)	55 5/8 (1413)	50 (1270)	5/8	1 3/8	781 (355)
061L6	3DA3A060E	40480	31980	-	40.0	18.2	14.0	41 7/8 (1064)	55 5/8 (1413)	50 (1270)	5/8	1 3/8	819 (372)
075L6	3DB3A075E	46550	37120	-	41.5	21.2	14.7	41 7/8 (1064)	65 1/8 (1654)	50 (1270)	5/8	1 3/8	827 (376)
090L6	3DF3F40KE	58500	46200	-	50.5	23.1	21.4	41 7/8 (1064)	65 1/8 (1654)	50 (1270)	5/8	1 3/8	885 (401)
100L6	3DS3F46KE	64500	51400	-	56.7	25.5	22.8	41 7/8 (1064)	65 1/8 (1654)	50 (1270)	5/8	1 3/8	885 (401)
120L6	4DA3F47KE	69400	55000	-	64.2	31.9	24.6	45 1/2 (1156)	75 7/8 (1927)	59 (1156)	7/8	1 5/8	1185 (538)
150L6	4DL3F63KE	88300	71200	-	73.0	36.3	28.9	45 1/2 (1156)	75 7/8 (1927)	59 (1156)	7/8	1 5/8	1185 (538)
220L6	4DT3F76KE	102700	83000	-	87.6	43.5	32.9	45 1/2 (1156)	75 7/8 (1927)	59 (1156)	7/8	2 1/8	1185 (538)

SST = Saturated Suction Temperature

* Dimensions and weights shown are for outdoor units. Indoor units may be smaller/lighter. Consult Product Data and Specifications for details

CONDENSING UNITS

BEH-Line, Indoor/Outdoor Air Cooled Hermetic Condensing Units

Models range in capacity from 1/2 HP to 7 1/2 HP for high/medium, extended medium and low temperature applications. Models are available with Copeland, Maneurop or Tecumseh compressors and many standard features all built into a spacious serviceable design.



R404A R507 R407C

115/1/60, 208-230/1/60, 208-230/3/60, 460/3/60, 575/3/60, 200-220/1/50, 200-220/3/50 and 380/3/50

Five factory-installed option packages have been pre-selected for your convenience, plus the BEH unit offers the flexibility to create your own package.

COPELAND - **R404A R507** EXTENDED MEDIUM TEMPERATURE

MODEL BEHA	COMPR. MODEL	BTUH @95°F Amb.		MINIMUM CIRCUIT AMPACITY				DIMENSIONS In. (mm)			CONN.		Approx. Ship Weight - lbs. (kg)
		25°F SST	0°F SST	115/1/60	208-230/1/60	208-230/3/60	460/3/60	HEIGHT	WIDTH	DEPTH	LIQ.	SUCT.	
006E6	RS43C2E	6330	3620	12.6	6.5	-	-	16 7/8 (429)	24 7/8 (632)	34 3/8 (873)	3/8	5/8	149 (68)
008E6	RS55C2E	7840	4470	16.1	7.3	-	-	16 7/8 (429)	24 7/8 (632)	34 3/8 (873)	3/8	5/8	149 (68)
009E6	RS64C2E	8660	5230	14.8	9.2	-	-	16 7/8 (429)	24 7/8 (632)	34 3/8 (873)	3/8	5/8	152 (69)
010E6	RS70C1E	9490	5610	-	8.4	5.8	-	16 7/8 (429)	24 7/8 (632)	34 3/8 (873)	3/8	5/8	167 (76)
015E6	CS10K6E	15200	8060	-	13.4	9.5	4.6	19 7/8 (505)	36 3/8 (924)	34 3/8 (873)	3/8	5/8	279 (127)
020E6	CS12K6E	17400	9300	-	13.4	9.5	-	19 7/8 (505)	36 3/8 (924)	34 3/8 (873)	3/8	5/8	282 (128)
025E6	CS14K6E	20300	11600	-	15.1	11.4	5.9	19 7/8 (505)	36 3/8 (924)	34 3/8 (873)	1/2	7/8	286 (130)
029E6	CS18K6E	24600	13800	-	19.0	11.0	5.9	19 7/8 (505)	36 3/8 (924)	34 3/8 (873)	1/2	7/8	292 (132)
030E6	CS18K6E	27700	15000	-	20.1	12.0	6.4	30 3/8 (772)	47 3/8 (1203)	43 (1092)	1/2	7/8	388 (176)
035E6	CS20K6E	30800	16500	-	23.0	14.9	6.9	30 3/8 (772)	47 3/8 (1203)	43 (1092)	1/2	7/8	389 (176)
040E6	CS27K3E	37900	21000	-	28.9	19.6	10.6	30 3/8 (772)	47 3/8 (1203)	43 (1092)	1/2	7/8	389 (176)
050E6	CS33K3E	43700	25100	-	36.6	23.1	12.2	30 3/8 (772)	47 3/8 (1203)	43 (1092)	1/2	7/8	398 (181)

COPELAND - **R404A R507** LOW TEMPERATURE

MODEL BEHA	COMPR. MODEL	BTUH @95°F Amb.		MINIMUM CIRCUIT AMPACITY				DIMENSIONS In. (mm)			CONN.		Approx. Ship Weight - lbs. (kg)
		-10°F SST	-20°F SST	115/1/60	208-230/1/60	208-230/3/60	460/3/60	HEIGHT	WIDTH	DEPTH	LIQ.	SUCT.	
006L6	AFT22C1E	2730	2090	11.6	4.7	-	-	16 7/8 (429)	24 7/8 (632)	34 3/8 (873)	3/8	1/2	141 (64)
008L6	AFT26C1E	3380	2550	11.1	5.7	-	-	16 7/8 (429)	24 7/8 (632)	34 3/8 (873)	3/8	5/8	152 (69)
010L6	CF04K6E	5150	3710	-	12.9	8.1	-	16 7/8 (429)	24 7/8 (632)	34 3/8 (873)	3/8	5/8	165 (75)
020L6	CF06K6E	8100	5910	-	13.3	8.4	-	16 7/8 (429)	24 7/8 (632)	34 3/8 (873)	3/8	7/8	194 (88)
025L6	CF09K6E	12500	9100	-	19.9	12.6	6.8	19 7/8 (505)	36 3/8 (924)	34 3/8 (873)	3/8	7/8	281 (127)
030L6	CF12K6E	15200	11600	-	24.1	14.9	8.0	19 7/8 (505)	36 3/8 (924)	34 3/8 (873)	1/2	7/8	292 (132)

COPELAND - **R407C** HIGH & MEDIUM TEMPERATURE

MODEL BEHA	COMPR. MODEL	BTUH @95°F Amb.		MINIMUM CIRCUIT AMPACITY				DIMENSIONS In. (mm)			CONN.		Approx. Ship Weight - lbs. (kg)
		35°F SST	10°F SST	208-230/1/60	208-230/3/60	460/3/60	575/3/60	HEIGHT	WIDTH	DEPTH	LIQ.	SUCT.	
015H7	CR18KQE	14600	7630	11.2	7.9	-	-	19 7/8 (505)	36 3/8 (924)	34 3/8 (873)	3/8	5/8	277 (126)
020H7	CR24KQE	18300	9610	16.3	9.5	4.8	-	19 7/8 (505)	36 3/8 (924)	34 3/8 (873)	3/8	5/8	282 (128)
025H7	CR32KQE	24000	12600	20.2	12.2	6.3	-	19 7/8 (505)	36 3/8 (924)	34 3/8 (873)	3/8	7/8	292 (132)
029H7	CR37KQE	26800	13400	21.9	13.5	6.9	-	19 7/8 (505)	36 3/8 (924)	34 3/8 (873)	1/2	7/8	298 (135)
030H7	CR37KQE	29600	14600	22.9	14.5	7.4	-	30 3/8 (772)	43 7/8 (1114)	43 (1092)	1/2	7/8	394 (179)
035H7	CR41KQE	32200	15900	23.8	16.8	7.8	6.7	30 3/8 (772)	43 7/8 (1114)	43 (1092)	1/2	7/8	394 (179)
040H7	CR53KQE	39800	19900	34.6	22.5	11.3	-	30 3/8 (772)	43 7/8 (1114)	43 (1092)	1/2	1 1/8	405 (184)
050H7	CRN0-050E	50000	26800	40.6	26.1	11.9	9.7	30 3/8 (772)	43 7/8 (1114)	43 (1092)	1/2	1 1/8	415 (188)

SST = Saturated Suction Temperature

* Dimensions and weights shown are for outdoor units. Indoor units may be smaller/lighter. Consult Product Data and Specifications for details

CONDENSING UNITS

BEZ-Line, Indoor/Outdoor Air Cooled Scroll Condensing Units

Models range in capacity from 1 HP to 15 HP for high, medium and low temperature applications. BEZ units are available with Copeland scroll compressors and come complete with many standard features.

In addition to the numerous options available and following the convention of our other BE product lines, there are five factory-installed option packages we've pre-selected for your convenience.



R404A R507 R407C

208-230/1/60, 208-230/3/60, 460/3/60,
575/3/60, 200-220/1/50, 200-220/3/50
and 380/3/50

COPELAND - R404A R507 MEDIUM TEMPERATURE

MODEL BEZA	COMPR. MODEL	BTUH @ 95°F Amb.		MINIMUM CIRCUIT AMPACITY				DIMENSIONS In. (mm)			CONN.		Approx. Ship Weight - lbs. (kg)
		25°F SST	0°F SST	208-230/1/60	208-230/3/60	460/3/60	575/3/60	HEIGHT	WIDTH	DEPTH	LIQ.	SUCT.	
010M6	ZB10KCE	12000	7400	13.0	-	-	-	16 7/8 (429)	24 7/8 (632)	34 3/8 (873)	3/8	5/8	200 (91)
011M6	ZB11KCE	14000	8500	13.6	-	-	-	19 7/8 (505)	36 3/8 (924)	34 3/8 (873)	3/8	5/8	285 (129)
015M6	ZB13KCE	16500	9600	17.2	-	-	-	19 7/8 (505)	36 3/8 (924)	34 3/8 (873)	3/8	7/8	285 (129)
020M6	ZB15KCE	18200	11400	20.7	12.2	6.9	-	19 7/8 (505)	36 3/8 (924)	34 3/8 (873)	3/8	7/8	300 (136)
025M6	ZB19KCE	22700	14200	23.5	13.6	6.9	-	19 7/8 (505)	36 3/8 (924)	34 3/8 (873)	1/2	7/8	320 (145)
030M6	ZB21KCE	28400	17600	28.0	17.2	8.7	7.2	30 3/8 (772)	47 3/8 (1203)	43 (1092)	1/2	1 1/8	410 (186)
035M6	ZB26KCE	32500	20200	31.6	19.5	10.0	8.0	30 3/8 (772)	47 3/8 (1203)	43 (1092)	1/2	1 1/8	415 (188)
040M6	ZB30KCE	36300	22300	35.6	21.7	10.5	8.4	30 3/8 (772)	47 3/8 (1203)	43 (1092)	1/2	1 1/8	420 (191)
050M6	ZB38KCE	45400	28500	41.0	29.7	13.1	10.5	30 3/8 (772)	47 3/8 (1203)	43 (1092)	1/2	1 1/8	425 (193)
060M6	ZB45KCE	55200	34400	-	30.2	15.5	12.4	30 3/8 (772)	47 3/8 (1203)	43 (1092)	5/8	1 3/8	470 (213)
076M6	ZB56KCE	64900	41100	-	39.6	20.7	15.2	41 7/8 (1064)	55 5/8 (1413)	43 (1092)	5/8	1 3/8	510 (231)
085M6	ZB76KCE	89900	57200	-	56.0	27.2	19.1	41 7/8 (1064)	55 5/8 (1413)	43 (1092)	5/8	1 3/8	515 (234)
110M6	ZB95KCE	114400	70700	-	73.3	36.4	26.9	45 1/2 (1156)	75 7/8 (1927)	45 1/2 (1156)	7/8	1 3/8	635 (288)
150M6	ZB114KCE	132400	82000	-	85.8	43.5	32.3	45 1/2 (1156)	75 7/8 (1927)	45 1/2 (1156)	7/8	1 5/8	645 (293)

COPELAND - R404A R507 LOW TEMPERATURE

MODEL BEZA	COMPR. MODEL	BTUH @ 95°F Amb.		MINIMUM CIRCUIT AMPACITY				DIMENSIONS In. (mm)			CONN.		Approx. Ship Weight - lbs. (kg)
		-10°F SST	-20°F SST	208-230/1/60	208-230/3/60	460/3/60	575/3/60	HEIGHT	WIDTH	DEPTH	LIQ.	SUCT.	
020L6	ZF06K4E	9600	7800	17.5	12.1	-	-	19 7/8 (505)	36 3/8 (924)	34 3/8 (873)	3/8	7/8	315 (143)
025L6	ZF08K4E	12200	9900	21.6	13.2	6.9	-	19 7/8 (505)	36 3/8 (924)	34 3/8 (873)	3/8	7/8	335 (152)
030L6	ZF09K4E	13500	11000	21.6	15	7.7	5.9	19 7/8 (505)	36 3/8 (924)	34 3/8 (873)	3/8	7/8	425 (193)
035L6	ZF11K4E	16300	13300	27	18.1	9.5	6.8	19 7/8 (505)	36 3/8 (924)	34 3/8 (873)	1/2	1 1/8	430 (195)
045L6	ZF13K4E	19200	15400	35.6	20.9	11.4	11.2	30 3/8 (772)	47 3/8 (1203)	43 (1092)	1/2	1 1/8	435 (197)
055L6	ZF15K4E	23100	18800	41.9	28.9	13.1	10.8	30 3/8 (772)	47 3/8 (1203)	43 (1092)	1/2	1 1/8	440 (200)
060L6	ZF18K4E	28000	22800	-	32	12.7	10.8	30 3/8 (772)	47 3/8 (1203)	43 (1092)	1/2	1 3/8	485 (220)
075L6	ZF24K4E	34500	27900	-	39.6	20.7	12	41 7/8 (1064)	55 5/8 (1413)	43 (1092)	5/8	1 3/8	495 (225)
100L6	ZF33K4E	46900	38100	-	56.6	27.5	21	41 7/8 (1064)	55 5/8 (1413)	43 (1092)	5/8	1 3/8	545 (247)
130L6	ZF40K4E	57200	46800	-	60.5	29.8	26.8	41 7/8 (1064)	68 5/8 (1743)	43 (1092)	5/8	1 3/8	725 (329)
150L6	ZF48K4E	64800	52700	-	73	32.6	26.3	41 7/8 (1064)	68 5/8 (1743)	43 (1092)	5/8	1 3/8	745 (338)

SST = Saturated Suction Temperature

* Dimensions and weights shown are for outdoor units. Indoor units may be smaller/lighter. Consult Product Data and Specifications for details